

Replacing an Internal Nonmirrored Disk Drive CRU



This procedure describes how to replace an internal nonmirrored disk drive CRU in a NonStop S-series server online. You might need to replace a disk drive CRU if it has failed or partially failed or if you are upgrading the disk drives. You do not need to shut down the system before replacing a disk drive CRU.

The following is a high-level summary of the tasks required to complete the replacement procedure. Each task in this summary is linked to step-by-step instructions about how to perform that task.

Whenever you handle an internal disk drive CRU, you should follow [standard operating practices](#) to avoid damage to the equipment.

- 1 If the disk drive CRU is functioning, prepare it for removal:
 - a Log on to the system as the super ID (255,255) or as the owner of the application that is using the disk drive.
 - b Determine whether the disk drive contains SQL files.

Use the DSAP VOLUME, SQL command, for example:

If DSAP reports any SQL files, contact your database administrator before stopping the disk drive.

 **Note:** You must add the NEWFORMAT option for disk drives larger than 18 GB. For example, if \$D0411 were a 36 GB disk drive, you would type:

```
14> DSAP $D0411, SQL, NEWFORMAT
```

 **Caution:** Removing a disk drive that contains SQL files can make the SQL database unusable.

- c Stop all application software that is using the disk drive.
- d Back up the data to tape using the BACKUP utility.

- e Stop the disk drive using either OSM, TSM, or SCF:
 - OSM: Stop Disk action
 - TSM: Down action
 - SCF command: [STOP DISK](#)
- 2 Identify the group, module, and slot containing the disk drive CRU, using OSM, TSM, or SCF:
 - OSM or TSM: check disk attributes
 - SCF command: [STATUS DISK, DETAIL](#)
- 3 [Power off and remove the disk drive CRU](#) (it weighs nearly 4 pounds, or 2 kilograms).



Caution: After using the OSM or TSM Power Off action, wait until the disk stops spinning before removing the disk. Removing a disk drive while it is still spinning can seriously damage the disk.

- 4 [Install the replacement disk drive CRU.](#)



Cautions

- Before you install a CRU, carefully check its connecting pins. If any pins are bent or damaged, do not install the CRU. Doing so could damage the backplane. See *Avoiding Connector and Backplane Damage During CRU/FRU Replacement* (NTL Support and Service > Service Procedures) for more information.
 - The disk drive CRU is extremely fragile. Do not force it into the slot.
- 5 After successful installation, write the logical name of the disk drive on the label near the top of the disk drive CRU faceplate.
 - 6 If this is a new disk or a previously used disk requiring a new label, create a new label identifying the disk (using the SCF ALTER DISK, LABEL command). For example, the following command changes the volume name of a disk from \$DATA00 to \$SPARE00:

```
-> ALTER $DATA00, LABEL $SPARE00
```



Caution: The SCF ALTER DISK, LABEL command deletes all files from the disk.

7 Resume operations on the replacement disk drive:

- a Start the disk drive and check its status using OSM, TSM, or SCF:
 - OSM: use Start Disk action and check disk attributes
 - TSM: use the Up action and check disk attributes
 - SCF commands: [RESET DISK](#), [START DISK](#), and [STATUS DISK](#)
- b [Test all disk paths](#) using SCF commands: (SWITCH DISK; PRIMARY DISK, FORCED; and STATUS DISK).
- c [Find bad sectors](#) on the replacement disk using the SCF command INFO DISK, BAD.

Mark any bad sectors found (using SCF CONTROL DISK, SPARE).

- d Restore data to the disk drive from your latest backup using the RESTORE utility.

 **Note:** Because the disk drive you replaced was operating as a nonmirrored volume, data written to it since the last backup is lost (unless you were able to retrieve that data).

- e Restart the application software that uses this disk drive.

Other Sources of Information

- Recovering From SCF Object States and Substates (NTL Support and Service > Troubleshooting Tips)
- Disk Drive Errors and Failure Recovery (NTL Support and Service > Troubleshooting Tips > NonStop S-Series Hardware Servicing)
- Enclosure Loses Power During Disk Insertion (NTL Support and Service > Troubleshooting Tips > NonStop S-Series Hardware Servicing)

Publications:

- *SCF Reference Manual for the Storage Subsystem*: provides detailed information for the SCF commands used in this procedure, as well as many options and attributes not discussed here.
- *Guardian Disk and Tape Utilities Reference Manual*: provides detailed information for the Disk Space Analysis Program (DSAP) utility.
- *OSM User's Guide*: gives step-by-step instructions for the OSM actions listed in this topic.
- *TSM Online User Guide*: gives step-by-step instructions for the TSM actions listed in this topic.

Change History for Replacing an Internal Nonmirrored Disk Drive CRU

[Topic Home](#)

September 6, 2005

Updated topic references with their NTL location.

September 24, 2003

Updated TSM references to include OSM.

June 2, 2003

Changed references from the obsolete NonStop S-Series Hardware Support Guide to references to CSSI topics.

March 19, 2001

- Corrected the command for creating a new label for a disk volume.
- Added a note stating that you must use the NEWFORMAT option with the DSAP VOLUME, SQL command for disk drives larger than 18 GB.

March 9, 2001

- Included both TSM actions and SCF commands when available.
- Included other sources of information.
- Included a note about upgrading to larger capacity disks.
- Added step for labeling the replacement disk drive.

October 6, 1998

- The instruction page for Installing an Internal Disk Drive CRU has been modified as follows:

The statement about checking for damaged pins has changed. There are two connectors located on the rear of an internal disk drive. The large data connector does not have pins. The smaller, square 24-pin power connector has pins that need to be checked.

- The titles of all instruction pages have been modified to correctly state the page content and to conform with the CSSI style.

August 5, 1998

Step 2 of the instruction page, To Test Nonmirrored Disk Paths, has been changed. The CPU parameter has been added to the PRIMARY command line.

June 12, 1998

- Corrected the procedure for testing disk paths. Testing now comes after starting the disk.
- Added the FORCED keyword after the SCF PRIMARY command to ensure correct processor ownership.
- Made minor changes to all example SCF output.

Standard Operating Practices



Caution. Replace only one CRU or FRU at a time. Attempting to replace more than one hardware component at a time might cause serious system outages, processor halts, and connectivity problems.

Whenever you replace a CRU or a FRU, use the following standard operating practices to minimize any potential damage to the equipment:

- Complete HP training courses on system support for NonStop S-series servers.
- Inspect the replacement CRU or FRU for any physical damage before installing it. Check the connectors on the CRU, FRU, or backplane for bent or broken pins and for any other obvious damage. If there is damage to the CRU or FRU, you need to order another one.
- Remove all jewelry and metal accessories, such as rings, watches, and necklaces, before working with the equipment. These items can damage electrical equipment or result in personal injury.
- Restrain any dangling items that can get caught in electromechanical equipment, such as long hair and sleeves, before working with the equipment.
- Follow the [ESD Guidelines](#) for working in an electrostatic discharge (ESD)-protected environment and for handling CRUs and FRUs.
- Avoid permanent damage to components from overheating by observing the time limits for an enclosure door to be open with only one fan running.

The following table indicates the amount of time that components in a fully loaded NonStop S-series system enclosure, with the appearance-side door open and only one fan operating, can operate before overheating.

Safe Operating Times With Enclosure Door Open

Altitude	Ambient Room Temperature			
	25°C (77°F)	30°C (86°F)	35°C (95°F)	38°C (100°F)
Sea level	>45 minutes	36 minutes	21 minutes	13 minutes
1,524 meters (5,000 feet)	38 minutes	22 minutes	13 minutes	8 minutes
3,048 meters (10,000 feet)	25 minutes	14 minutes	10 minutes	5 minutes

For example, if your computer room has an ambient room temperature of 25°C (77°F) and is at an altitude of 1,524 meters (5,000 feet), you have approximately 38 minutes to replace or reinstall the second fan before components inside a system enclosure overheat.

Related Topic

[ESD Guidelines](#)

ESD Guidelines



Figure: [Working in an ESD-Protected Environment](#)

Observe the following electrostatic discharge (ESD) guidelines whenever servicing electronic components:

- Obtain an ESD protection kit and follow the directions that come with the kit. You can purchase an ESD kit from HP (T99247-A00) or from a local electronics store. Ensure that your ESD wriststrap has a built-in series resistor and that the kit includes an antistatic table mat.
- Before you unpack a replacement CRU or FRU, place the CRU or FRU package on the antistatic table mat and attach the grounding clip on your wriststrap to the mat.
- When you unpack the CRU or FRU, do not cut into the ESD protective bag surrounding the CRU or FRU. The protective bag protects the CRU or FRU and can be reused for storing the CRU or FRU that has been replaced.
- Before you move the CRU or FRU from the antistatic table mat, attach the grounding clip from your ESD wriststrap to any unpainted metal surface on the CRU or FRU frame.
- Before you bring a CRU or FRU in contact with a system enclosure, attach the grounding clip on your ESD wriststrap to any unpainted metal surface on the enclosure frame.
- When you remove a CRU or FRU from a system enclosure, first pull the CRU or FRU partway out of the slot and then attach the grounding clip on your ESD wriststrap to any unpainted metal surface on the CRU or FRU frame.
- Store CRUs or FRUs that require ESD protection in ESD protective bags.
- The figure [Working in an ESD-Protected Environment](#) illustrates how to use an ESD kit when servicing CRUs or FRUs.

i Note: An ESD protection kit can be purchased from HP using the following order number and part number:

Order Number: ESD-kit

Part Number: T99247-A00

Related Topic

[Standard Operating Practices](#)

Figure: Working in an ESD-Protected Environment

This figure illustrates how to use an ESD kit when servicing customer-replaceable units (CRUs) and field-replaceable units (FRUs).

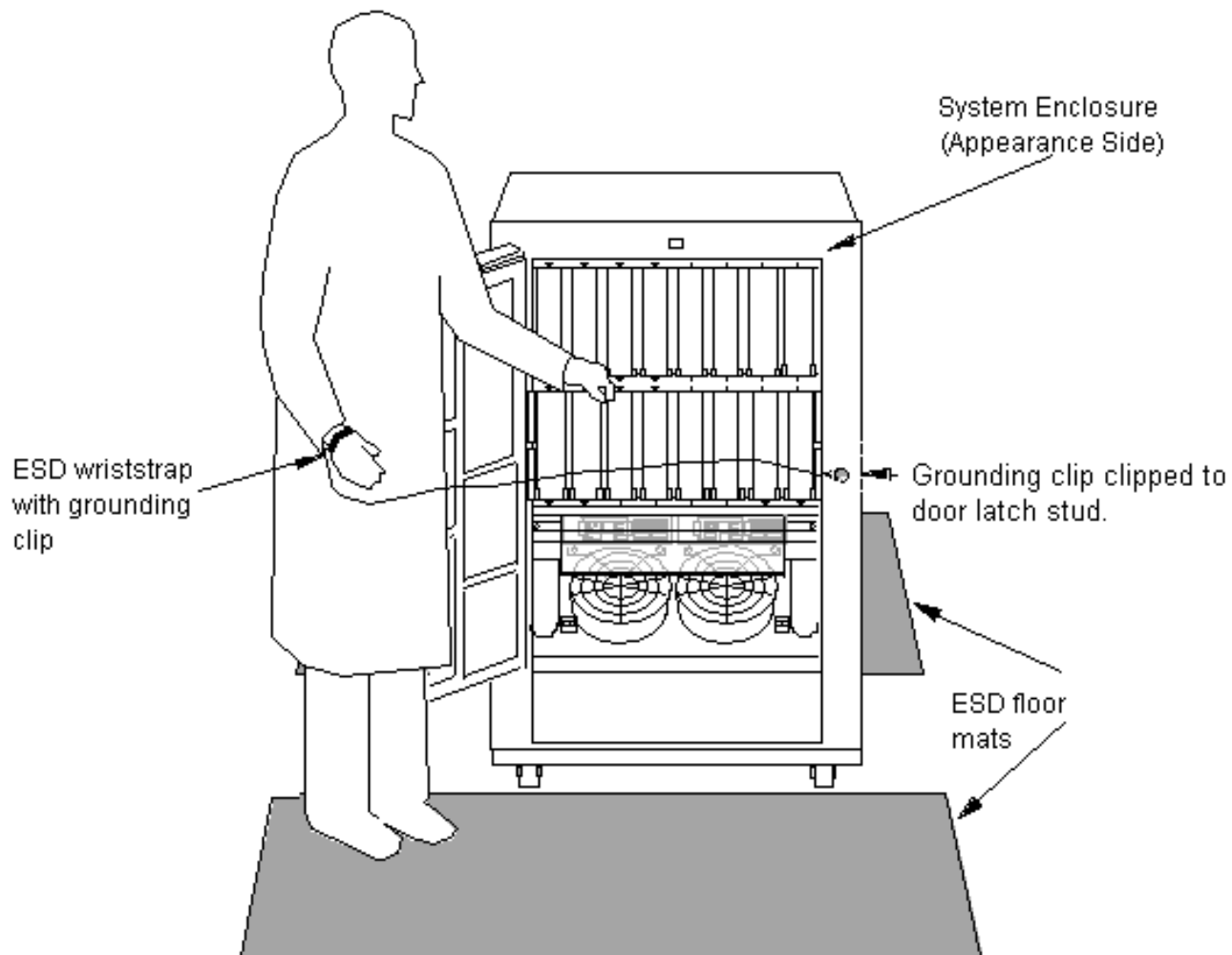

ESD antistatic table mat.
Mat should be connected
to a soft ground (1 megohm min.
to 10 megohm max.)

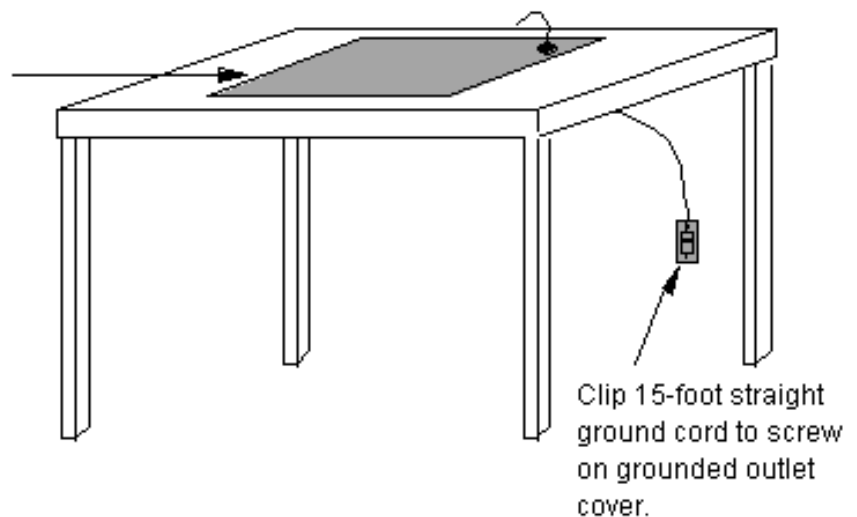

Stopping a Nonmirrored Disk Drive Using SCF

Topic Home

Follow these instructions to stop a nonmirrored disk drive. In this example, the \$DATA21 disk drive is being stopped to prepare it for replacement.

If the disk drive is currently in the STARTED state, issue the SCF STOP DISK command, and type **Y** in response to the SCF prompt that asks if you want to stop the disk. Then use the STATUS DISK command to verify that the disk is in the STOPPED state, DOWN or HARDDOWN substate:

```
TACL>SCF STOP $DATA21
STORAGE W01007 The STOP DISK \TOYS.$DATA21 operation will cause
\TOYS.$DATA21
to be INACCESSIBLE to user processes.
Do you want to STOP DISK \TOYS.$DATA21 (Y/[N])Y
->STATUS $DATA21-*
STORAGE - Status DISK \TOYS.$DATA21-*
  LDev  Path          Status      State      Substate      Primary
Backup
      87  PRIMARY      INACTIVE   STOPPED   DOWN          PID
3,262                                     2,262
      87  BACKUP      INACTIVE   STOPPED   DOWN          PID
3,262                                     2,262
->
```

Locating an Internal Nonmirrored Disk Drive Using SCF

[Topic Home](#)

Use the SCF STATUS DISK, DETAIL command to determine the physical location (group, module, slot) of an internal nonmirrored disk drive.

```
TACL> SCF STATUS $DATA21, DETAIL
STORAGE - Detailed Status DISK \TOYS.$DATA21
```

Disk Path Information:

LDev	Path	Status	State	Substate	Primary PID	Backup PID
87	PRIMARY	ACTIVE	STARTED		2,262	3,262
87	BACKUP	INACTIVE	STARTED		2,262	3,262

General Disk Information:

```
Device Type..... 3           Device Subtype..... 42
Primary Drive Type.... 4608-1   Mirror Drive Type.....
Physical Record Size.. 4096     Priority..... 220
Library File.....
Program File..... $SYSTEM.SYS00.TSYSDP2
Protection.....
```

Usage Information:

```
Capacity (MB)..... 8837.85   Free Space (MB)..... 8836.73 (99.98%)
Free Extents..... 2           Largest Free Extent (MB). 8836.71
```

Hardware Information:

Device	Location (group,module,slot)	Power	Physical Status
PRIMARY	(2,1,1)	DUAL	PRESENT

In this example, under Hardware Information, the output shows that \$DATA21 is located in group 02, module 01, slot 01.

Powering Off and Removing an Internal Disk Drive CRU

Mirrored Home



Nonmirrored Home

Next Step

Follow these instructions to power off and remove an internal disk drive customer-replaceable unit (CRU).

- 1 [Gather the proper tools](#) you will use to replace the disk drive CRU.
- 2 Use the OSM or TSM **Power Off** action to power off the disk drive.
- 3 Follow [standard operating practices](#) when handling a disk drive CRU.
- 4 Unlock and open the appearance-side enclosure door.



Caution: Minimize the time the enclosure door is open to avoid overheating other components in the enclosure. Refer to [Safe Operating Times With Enclosure Door Open](#).

- 5 Attach the grounding clip of the ESD wriststrap to any unpainted metal on the enclosure frame, such as the door latch stud.
- 6 Make sure that the green power-on LED on the disk drive CRU is unlit and that the disk drive has stopped spinning.



Caution: Removing a disk drive CRU while it is still spinning can seriously damage the disk.

- 7 Simultaneously loosen both thumbscrews on the faceplate of the disk drive CRU . Use a Phillips screwdriver to loosen the screws, if necessary.
- 8 Grasp both thumbscrews and gently pull the disk drive CRU partway out of its slot, rocking the CRU with a slight up-and-down motion until the CRU is unseated from the backplane.

- 9 Pull the disk drive CRU out far enough that you can support the bottom of the CRU with one hand (the CRU weighs 3.5 pounds, or 1.6 kilograms) while holding on to one of the thumbscrews with the other hand.



Caution: The disk drive CRU is extremely fragile. Do not drop it, and do not subject it to sudden jarring movements.

- 10 Carefully lift the disk drive CRU all the way out of its slot and set it on its side on the antistatic mat. Detach the grounding clip of your ESD wriststrap.
- 11 Immediately [install the replacement disk drive CRU](#), or close the enclosure door until you are ready to install the replacement CRU. Refer to [Safe Operating Times With Enclosure Door Open](#) for more information.

Replacing an Internal Mirrored Disk Drive CRU



This procedure describes how to replace an internal mirrored disk drive CRU online. You might need to replace a CRU if it has failed, partially failed, or if you are upgrading the disk drives. You do not need to shut down the system before replacing a disk drive CRU.

! **Caution:** On pre-G06.24 RVUs that are not running SPR T9753AFN or later, disable DBIO before stopping or disconnecting a mirrored drive. Although a failure is rare, resuming operations on a mirrored drive could corrupt the volume label on both the primary and mirror drives. All paths to the disk volume might enter a hard down state and cause a system or application outage if:

- The primary and mirror drive are in the same enclosure.
- Both active paths are from the same ServerNet fabric (if the PRIMARY and MIRRORBACKUP or the BACKUP and MIRROR paths are active).
- If a ServerNet chip fails while the volume label is being updated.

Instructions for disabling and re-enabling DBIO are included in Steps 4 and 10. This precaution is unnecessary if G06.24 or SPR T9753AFN and later are configured and running.

i **Note:** To avoid rare outages caused by volume label corruption on pre-G06.24 RVUs, install SPR T9753AFR or its superseding SPR. This SPR supersedes T9753AFN.

The following is a high-level summary of the tasks required to complete the replacement procedure. Each task in this summary is linked to step-by-step instructions about how to perform that task.

Whenever you handle an internal disk drive CRU, follow [standard operating practices](#) to avoid damage to the equipment.

! **Caution:**

- 1 Read the important [Notes for Replacing an Internal Mirrored Disk Drive CRU](#).

- 2 Prepare the mirrored disk drive CRU for removal (necessary only if both primary and mirrored disk drives are functioning):
 - a Verify that paths to the other half of the mirrored volume are up, using OSM, TSM, or SCF:
 - OSM or TSM: check disk attributes
 - SCF command: [STATUS DISK](#)
 - b Before replacing the mirrored disk, be sure that it has no checksum errors on the other half of the mirrored volume. Use the OSM or TSM Validate Checksum action to check for errors.

Your service provider can update the checksum value using SCF (the CONTROL DISK, CHECKSUM command). Do not replace the mirrored disk until all checksum errors are corrected.

- c [Check for \(and spare\) bad sectors on the other half of the mirrored volume](#), using the SCF INFO DISK, BAD and SCF CONTROL DISK, SPARE commands.



Caution: If possible, stop all processing on the mirrored volume before sparing any of its sectors. The CONTROL DISK, SPARE command can cause inconsistent data if the volume is being used when you issue the command. For this reason, SCF asks you to confirm the request before it spares a sector.

- d If it has not already stopped due to malfunction, stop the disk drive using OSM, TSM, or SCF:
 - OSM: Stop Disk action
 - TSM: Down action
 - SCF command: [STOP DISK](#)
- 3 Identify the group, module, and slot containing the disk drive CRU using OSM, TSM, or SCF:
 - OSM or TSM: check disk attributes
 - SCF command: [STATUS DISK, DETAIL](#)

4 Disable DBIO on pre-G06.24 systems that are not running SPR T9753AFN or later.

- First, determine the current state of DBIO by using the SCF Status SUBSYS \$ZZSTO command.
- Verify that the Backup and Restore utilities are not running. These programs might use DBIO, if it is enabled, for enhanced performance. Enter the TACL commands:
 - **Status ***, **PROG \$system.system.backup**
 - **Status ***, **PROG \$system.system.restore**
- Wait until all Backup and Restore processes have finished before disabling DBIO.

To disable DBIO, issue the **SCF ALTER SUBSYS \$ZZSTO, BULKIO OFF** command. Verify that it is disabled (OFF) by using the **info SUBSYS** command.

```
1> SCF
-> alter subsys $ZZSTO, BULKIO OFF
-> info subsys $zzsto
```

STORAGE - Info SUBSYS \$ZZSTO

AutoConfigure	AutoRevive	AutoStart	BulkIO	LabelTape	UPS
OFF	OFF	ON	OFF	ON	
OFF					

5 [Power off and remove the disk drive CRU](#) (it weighs nearly 4 pounds, or 2 kilograms).



Caution: After using the OSM or TSM Power Off action, wait until the disk stops spinning before removing the disk. Removing a disk drive while it is still spinning can seriously damage the disk.

6 [Install the replacement disk drive CRU](#).



Cautions:

- Before you install a CRU, carefully check its connecting pins. If any pins are bent or damaged, do not install the CRU. Doing so could damage the backplane. See *Avoiding Connector and Backplane Damage During CRU/FRU Replacement* (NTL Support and Service > Service Procedures) for more information.
- The disk drive CRU is extremely fragile. Do not force it into the slot.

- 7 After successful installation, write the logical name of the disk drive on the label near the top of the disk drive CRU faceplate.
- 8 Resume operations on the replacement mirrored disk drive:

- a Revive, monitor, and check the status of the disk drive using OSM, TSM, or SCF. The revive process is automatic and will create a label for the replacement disk:
 - OSM: use Start Volume action and check disk attributes
 - TSM: use the Up action and check disk attributes
 - SCF commands: [RESET DISK](#), [START DISK](#), and [STATUS DISK](#)

System and application software does not need to be restarted; the other half of the mirrored volume has been operational during the replacement procedure.

See [Notes for Replacing an Internal Mirrored Disk Drive CRU](#) for a description of the automatic STOPPED, HARDDOWN when upgrading to a disk drive of a larger capacity.



Caution: Wait until the disk is fully revived before performing the next step to test the disk paths. The revive operation might take quite a while — the time required depends on how much data resides on the disk. The revive operation can also slow system performance, especially for users of that mirrored volume.

- b [Test the disk paths](#) (using the SCF SWITCH DISK; SCF PRIMARY DISK, FORCED; and SCF STATUS DISK commands).
- 9 [Check for \(and spare\) bad sectors on the replacement disk](#), using the SCF INFO DISK, BAD and SCF CONTROL DISK, SPARE commands.



Caution: If possible, stop all processing on the mirrored volume before sparing any of its sectors. The CONTROL DISK, SPARE command can cause inconsistent data if the volume is being used when you issue the command. For this reason, SCF asks you to confirm the request before it spares a sector.

10 Enable DBIO if it was disabled in Step 4.

```
1> SCF ALTER SUBSYS $ZZSTO, BULKIO ON
```

```
2> info subsys $zzsto
```

```
STORAGE - Info SUBSYS $ZZSTO
```

AutoConfigure	AutoRevive	AutoStart	BulkIO	LabelTape	UPS
OFF	OFF	ON	On	ON	OFF

Related Topics:

- [Recovering From SCF Object States and Substates \(NTL Support and Service > Troubleshooting Tips\)](#)
- [Disk Drive Errors and Failure Recovery \(NTL Support and Service > Troubleshooting Tips > NonStop S-Series Hardware Servicing\)](#)
- [Enclosure Loses Power During Disk Insertion \(NTL Support and Service > Troubleshooting Tips > NonStop S-Series Hardware Servicing\)](#)

Related Publications:

- *SCF Reference Manual for the Storage Subsystem*: provides detailed information on the SCF commands used in this procedure, as well as many options and attributes not discussed here.
- *Guardian Disk and Tape Utilities Reference Manual*: provides detailed information for the Disk Space Analysis Program (DSAP) utility.
- *OSM User's Guide*: gives step-by-step instructions for the OSM actions listed in this topic.
- *TSM Online User Guide*: gives step-by-step instructions for the TSM actions listed in this topic.

Change History for Replacing an Internal Mirrored Disk Drive CRU

Topic Home



February 13, 2006

Changed the OSM Start Disk action to the OSM Start Volume action. The Start Disk action is designed to fail if the mirrored disk is already in an Up state because the mirror and primary disk volumes can have different data and require a revive operation. To revive and bring up the disks properly, use the OSM Start Volume action or SCF START DISK command.

September 1, 2005

Updated Notes for Replacing an Internal Mirrored Disk Drive CRU to indicate that FCHECK should be used with H-series RVUs and G06.24 and later G-series RVUs. TANDUMP CMFILE should be used only with G06.23 and earlier RVUs.

November 30, 2004

Added caution to disable DBIO on pre-G06.24 systems that are not running SPR T9753AFN or later.

September 24, 2003

Updated TSM references to include OSM.

May 31, 2002

- Moved notes to a new Notes for Replacing an Internal Mirrored Disk Drive CRU page.
- Added a note stating that disk drives with different model numbers cannot remain as a mirrored pair. (If you are upgrading disk drives, you must upgrade the primary drive immediately after upgrading the

mirror disk drive.)

- Added a note stating that downgrading using the revive operation is not supported.
- Added links to related CSSI topics to Other Sources of Information.

December 12, 2001

- Added information on how to use TANDUMP/CMFILE to Detect Errors on Mirrored Disks.

March 19, 2001

Modified commands and report examples in Starting a Revive Operation on a Mirrored Disk Drive Using SCF.

March 9, 2001

- Included both TSM actions and SCF commands when available.
- Included other sources of information.
- Included a note about upgrading to larger capacity disks.
- Added step recommending user verify the disk checksum value on the mirror disk before replacing the defective disk.
- Added step for labeling the replacement disk drive.
- Added recommendation that user wait until revive is finished before switching disk paths.

November 19, 1998

The instruction page for Resetting and Verifying a Mirrored Disk Drive has changed to correct the reset command. Previously the command was RESET \$DATA17-M. For this example, the correct command is RESET \$DATA17.

October 6, 1998

- The instruction page for Installing an Internal Disk Drive CRU has been modified as follows:

The statement about checking for damaged pins has changed. There are two connectors located on the rear of an internal disk drive. The large data connector does not have pins. The smaller, square

24-pin power connector has pins that need to be checked.

- The titles of all instruction pages have been modified to correctly state the page content and to conform with the CSSI style.

August 5, 1998

Step 2 of the instruction page, To Test Mirrored Disk Paths, has been changed. The CPU parameter has been added to the PRIMARY command line.

June 12, 1998

- Moved the procedure for checking for bad sectors on the other half of the mirrored volume so that it comes before stopping the disk to be replaced.
- Corrected the procedure for testing disk paths. Testing now comes after starting the disk.
- Added the FORCED keyword after the SCF PRIMARY command to ensure correct controller ownership.
- Made minor changes to all example SCF output.

Notes for Replacing an Internal Mirrored Disk Drive CRU

[Topic Home](#)

Note: Certain rare events can occur during or after a disk drive replacement. Consult these documents:

- G06.24 and later (and H-series): DP2 FCHECK User's Guide (NTL Support and Service > Service Information)
- G06.23 and earlier: TANDUMP CMFILE (NTL Support and Service > Service Information > NonStop S-Series Hardware Servicing)

Note: If you are upgrading to a faster disk drive of a larger capacity, when the revive operation is complete on the mirror disk drive, then the primary disk drive (which has the lower capacity) is automatically brought down into the STOPPED state, HARDDOWN substate. You must then replace the primary disk drive immediately.

Note: The replacement disk drive you install as one half of a mirrored disk volume must have a model number identical to the remaining half of the disk volume, unless you are performing an upgrade. If you are upgrading disk drives, you must upgrade the primary drive immediately after upgrading the mirror disk drive. Disk drives with different model numbers cannot remain as a mirrored pair.

Note: Performing the revive operation to a smaller, slower disk drive (downgrading) is not supported.

Verifying That the Paths to the Other Half of a Mirrored Volume Are Up Using SCF

[Topic Home](#)

Use the SCF STATUS DISK command to verify the state of the paths to the other half of a mirrored volume. In this example, the mirror half of the volume \$DATA17 is to be replaced.

```
TACL>SCF STATUS $DATA17-*
```

```
STORAGE - Status DISK \TOYS.$DATA17-*
```

LDev	Path	Status	State	Substate	Primary PID	Backup PID
88	PRIMARY	ACTIVE	STARTED		1,266	0,282
88	BACKUP	INACTIVE	STARTED		1,266	0,282
88	MIRROR	ACTIVE	STARTED		1,266	0,282
88	MIRROR-BACKUP	INACTIVE	STARTED		1,266	0,282

```
->
```

Checking For and Sparing Bad Sectors on a Mirrored Disk Drive Using SCF

Topic Home

Follow these instructions to check for and spare bad sectors on a mirrored disk drive CRU when preparing to replace the other half of its mirrored volume. In this example, the mirror half of the volume \$DATA17 is to be replaced.

```
1  TACL> SCF INFO $DATA17, BAD
    STORAGE - Bad Sector Information Magnetic DISK \TOYS.$DATA17
```

Bad Sectors Information \$DATA17 Primary:

Logical Sector Address	Date Detected
%H0000795C	SEPTEMBER 22, 1996 15:25:12

File Name	File Address	Logical Sector Address
DLSYS42X.OSIMAGE	573440-573951	%H0000795C

Bad Sectors Information \$DATA17 Mirror:
No bad sectors found.

Bad sectors are listed under Logical Sector Address. If no bad sectors are found, skip the remaining steps on this page.

- 2 If the other half of the volume has bad sectors, you must spare them using the CONTROL DISK, SPARE command before you begin the disk drive revive operation:

```
->CONTROL $DATA17-P, SPARE %H795C
```



Caution: The CONTROL DISK, SPARE command can cause inconsistent data if the volume is being used when you issue this command. Stop all processing on the volume before issuing the CONTROL DISK, SPARE command, especially when sparing bad sectors on a system volume while one half of the volume is down.

- 3 If any files are associated with the bad sectors, you must restore them from your most recent backup of the disk volume, using the RESTORE utility.
- 4 Use the INFO DISK, BAD command again (that is, repeat [Step 1](#)) to verify that no new bad sectors have been introduced.

Stopping a Mirrored Disk Drive Using SCF

[Topic Home](#)

Follow these instructions to shut down both paths to a disk drive. In this example, the \$DATA17 mirror drive is being stopped to prepare it for replacement.

If the disk drive is currently in the STARTED state, use the SCF STOP DISK command to shut down both paths to the disk drive. Then use the STATUS DISK command to verify that the disk is in a STOPPED state, DOWN or HARDDOWN substate:

```
TACL>SCF STOP $DATA17-M
->STOP $DATA17-MB
->STATUS $DATA17-*
STORAGE - Status DISK \TOYS.$DATA17-*
  LDev  Path                Status      State      Substate    Primary
Backup
PID
  88    PRIMARY              ACTIVE      STARTED    1,266
0,282
  88    BACKUP                 INACTIVE    STARTED    1,266
0,282
  88    MIRROR                 INACTIVE    STOPPED    DOWN        1,266
0,282
  88    MIRROR-BACKUP          INACTIVE    STOPPED    DOWN        1,266
0,282
->
```

Locating an Internal Mirrored Disk Drive Using SCF

[Topic Home](#)

Use the SCF STATUS DISK, DETAIL command to determine the physical location (group, module, slot) of an internal mirrored disk drive.

```
TACL> SCF STATUS DISK $DATA17, DETAIL STORAGE - Detailed Status DISK
\TOYS.$DATA17 Disk Path Information: LDev Path Status State Substate
Primary Backup PID PID 88 PRIMARY ACTIVE STARTED 1,266 0,282 88 BACKUP
INACTIVE STARTED 1,266 0,282 88 MIRROR INACTIVE STOPPED DOWN 1,266 0,282 88
MIRROR-BACKUP INACTIVE STOPPED DOWN 1,266 0,282 General Disk Information:
Device Type..... 3 Device Subtype..... 42 Primary Drive
Type.... 4608-1 Mirror Drive Type..... Physical Record Size.. 4096
Priority..... 220 Library File..... Program File.....
$SYSTEM.SYS00.TSYS DP2 Protection..... MIRRORED Usage Information:
Capacity (MB)..... 8837.85 Free Space (MB)..... 8837.37 (99.99%)
Free Extents..... 3 Largest Free Extent (MB). 8785.39 Hardware
Information: Device Location Power Physical Status (group,module,slot)
PRIMARY (1,1,1) DUAL PRESENT MIRROR (1,1,2) DUAL PRESENT
```

In this example, under Hardware Information, the output shows that \$DATA17-M is located in group 01, module 01, slot 02.

Installing an Internal Disk Drive CRU

Mirrored Home



Nonmirrored Home

Previous Step

Follow these instructions to install an internal disk drive customer-replaceable unit (CRU).

- 1 Follow [standard operating practices](#) when handling the disk drive CRU.
- 2 Unlock and open the appearance-side enclosure door, if necessary.



Caution: Minimize the time the enclosure door is open to avoid overheating other components in the enclosure. Refer to [Safe Operating Times With Enclosure Door Open](#).

- 3 Attach the grounding clip of the ESD wriststrap to any unpainted metal on the enclosure frame, such as the door latch stud.
- 4 Check for any damaged pins on the square 24-pin power connector located on the rear of the disk drive CRU. Do not attempt to install a disk drive CRU that has damaged pins. For more information, see NTL Support and Service > *Avoiding Connector and Backplane Damage During CRU/FRU Replacement* [[NTL employee site link](#) | [NTL customer site link](#)]
- 5 Holding the CRU so that the green power-on LED is toward the top (one hand supporting the bottom of the CRU, while holding on to one of the thumbscrews with the other hand), insert the disk drive into the slot.
- 6 Slide the disk drive CRU into the slot until the CRU connects to the backplane.



Caution: The disk drive CRU is extremely fragile. Do not force the it into the slot.

- 7 Simultaneously tighten both thumbscrews on the faceplate of the disk drive CRU to seat the CRU against the backplane. Do not over-tighten the thumbscrews.

Once the CRU is properly connected to the backplane, a power-on self-test (POST) runs. The amber LED becomes lit, then flashes, but upon successful completion of the POST, only the green power-on LED remains lit.

If the POST fails, try reseating the CRU. If the POST fails a second time, try installing a different disk drive CRU.

- 8 Detach the grounding clip of your ESD wriststrap.
- 9 Close and lock the enclosure door.

Resetting and Verifying a Mirrored Disk Drive Using SCF

Topic Home

Follow these instructions to reset and verify a mirrored disk drive. In this example, the \$DATA17 mirror drive has just been replaced and is being prepared for a revive operation.

Use the SCF RESET DISK command; then use the SCF STATUS DISK command to verify that the disk drive is in the STOPPED state with the substate DOWN.

```
TACL>SCF RESET $DATA17
```

```
->STATUS $DATA17-*
```

```
STORAGE - Status DISK \TOYS.$DATA17-*
```

LDev	Path	Status	State	Substate	Primary	PID
Backup						
88	PRIMARY	ACTIVE	STARTED			1,266
0,282						
88	BACKUP	INACTIVE	STARTED			1,266
0,282						
88	MIRROR	INACTIVE	STOPPED	DOWN		1,266
0,282						
88	MIRROR-BACKUP	INACTIVE	STOPPED	DOWN		1,266
0,282						

```
->
```

Starting a Revive Operation on a Mirrored Disk Drive Using SCF

[Topic Home](#)

Follow these instructions to revive a mirrored disk drive. In this example, the \$DSMSCM mirror disk drive has been replaced and is being returned to operation.

Note: A revive operation might affect system performance, especially for users of the disk being revived.

- 1 Issue the SCF START DISK command, and type Y in response to the SCF prompt that asks whether you want to revive the disk drive:

```
TACL> SCF START $DSMSCM
STORAGE W01001 To START the disk, SCF must revive the information on
                \ALM171.$DSMSCM. This operation might IMPACT system
                performance, especially users of $DSMSCM.
Do you want to start a disk revive on \ALM171.$DSMSCM (Y/[N])Y
```

- 2 Use the STATUS DISK, DETAIL command to monitor the progress of the revive operation. For example to check the status of a revive operation on \$DSMSCM, type:

```
->STATUS $DSMSCM, DETAIL
```

The Revive Information subsection of the STATUS DISK, DETAIL report displays the current sector being revived, the revive interval, and the number of tracks per interval, as shown in the following example.

```
STORAGE - Detailed Status DISK \ALM171.$DSMSCM
```

```
Disk Path Information:
```

LDev	Path	Status	State	Substate	Primary PID	Backup PID
98	PRIMARY	ACTIVE	STARTED		0,21	1,15
98	BACKUP	INACTIVE	STARTED		0,21	1,15
98	MIRROR	ACTIVE	STARTING	REVIVE	0,21	1,15
98	MIRROR-BACKUP	INACTIVE	STARTING	REVIVE	0,21	1,15

```
General Disk Information:
```

```
Device Type..... 3                Device Subtype..... 41
Primary Drive Type... 4604-1        Mirror Drive Type..... 4604-1
Physical Record Size.. 4096        Priority..... 220
Library File.....
Program File..... $SYSTEM.SYS00.TSYS DP2
Protection..... AUDITED, MIRRORED
```

```
Revive Information:
```

```
Current Logical Sector..... %HFDC8 of %H7E5B71 (0%)
Blocks Per Interval..... 1
Interval..... 100 * 10 milliseconds
```

```
Usage Information:
```

```
Capacity (MB)..... 4238.96        Free Space (MB)..... 1524.41 (35.96%)
Free Extents..... 105            Largest Free Extent (MB). 1504.11
```

```
Hardware Information:
```

```
Device      Location                Power          Physical Status
           (group,module,slot)
```

PRIMARY	(1,1,13)	DUAL	PRESENT
MIRROR	(1,1,14)	DUAL	PRESENT

See the SCF Reference Manual for the Storage Subsystem for more information on the STATUS DISK, DETAIL report.

- 3 Use the STATUS DISK-* command to verify successful completion of the revive operation. Both the primary and mirror disk drives should show State to be STARTED, as shown in the following example:

```
->STATUS $DSMSCM-*
STORAGE - Status DISK \ALM171.$DSMSCM-*
LDev Path          Status      State      Substate      Primary Backup
PID              PID
  98 PRIMARY          ACTIVE     STARTED
  98 BACKUP          INACTIVE  STARTED
  98 MIRROR          ACTIVE     STARTED
  98 MIRROR-BACKUP  INACTIVE  STARTED
->
```

Switching and Testing Paths to a Mirrored Disk Drive Using SCF

Topic Home

Follow these instructions to test all the paths to a mirrored disk drive. In this example, the \$DATA17 mirror disk drive has been replaced. The -M and -MB paths are being tested before operations are resumed on the replacement disk drive CRU.

- 1 Use the SCF SWITCH DISK command to switch the replacement disk drive to its backup path; then use the SCF STATUS DISK command to verify that the disk path has been switched and is working properly:

```
TACL>SCF SWITCH $DATA17-MB
->STATUS $DATA17
STORAGE - Status DISK \TOYS.$DATA17
LDev   Primary   Backup   Mirror   MirrorBackup   Primary   Backup
                PID           PID
      88 *STARTED   STARTED   STARTED   *STARTED       1,266    0,282
->
```

- 2 Use the SCF PRIMARY DISK, FORCED command to switch the disk volume to its backup processor; then use the SCF STATUS DISK command to verify the operation:

```
->PRIMARY $DATA17, FORCED
->STATUS $DATA17
STORAGE - Status DISK \TOYS.$DATA17
LDev   Primary   Backup   Mirror   MirrorBackup   Primary   Backup
                PID           PID
      88 *STARTED   STARTED   STARTED   *STARTED       0,282    1,266
->
```

i Note: For G06.10 and earlier, including the FORCED keyword here ensures the correct processor ownership. For G06.11 and later, the FORCED keyword is not needed and has no effect.

- 3 Use the SCF SWITCH DISK command again to switch the replacement disk drive back to its primary path; then use the SCF STATUS DISK command to verify that the disk path has been switched and is working properly:

```
->SWITCH $DATA17-M
->STATUS $DATA17
STORAGE - Status DISK \TOYS.$DATA17
LDev   Primary   Backup   Mirror   MirrorBackup   Primary   Backup
                PID           PID
      88 *STARTED   STARTED   *STARTED   STARTED       0,282    1,266
->
```

- 4 Use the SCF PRIMARY DISK, FORCED command again to switch the disk volume back to its primary processor; then use the SCF STATUS DISK command to verify the operation:

```
->PRIMARY $DATA17, FORCED
->STATUS $DATA17
STORAGE - Status DISK \TOYS.$DATA17
LDev   Primary   Backup   Mirror   MirrorBackup   Primary   Backup
                PID           PID
    88   *STARTED   STARTED   *STARTED   STARTED         1,266     0,282
->
```

 **Note:** For G06.10 and earlier, including the FORCED keyword here ensures the correct processor ownership. For G06.11 and later, the FORCED keyword is not needed and has no effect.

Gathering the Proper Tools to Assist With CRU and FRU Replacement

You will need some or all of the following tools to replace a CRU or a FRU:

Tool	Used to...
Electrostatic discharge (ESD) wriststrap with grounding clip	Protect the CRU or FRU from damage caused by electrostatic discharge.
Antistatic mat (recommended)	Provide a static-free environment for removal and installation of a CRU or FRU.
Flashlight	Check the connectors for bent or broken pins.
Phillips screwdriver	Loosen the captive thumbscrews on a disk drive CRU.

 **Note:** An ESD protection kit can be purchased from HP using the following order number and part number:

Order Number: ESD-kit

Part Number: T99247-A00

Resetting and Verifying Nonmirrored Disk Drive Using SCF

[Topic Home](#)

Follow these instructions to reset and verify a non mirrored disk drive. In this example, the \$DATA21 drive has just been replaced and is being prepared for operation.

Use the SCF RESET DISK command; then use the SCF STATUS DISK command to verify that the disk drive is in the STOPPED state with the substate DOWN.

```
TACL> SCF RESET $DATA21
->STATUS $DATA21-*
STORAGE - Status DISK \TOYS.$DATA21-*
LDev Path          Status          State          Substate          Primary
Backup
      87  PRIMARY          INACTIVE          STOPPED          DOWN              PID
3,262                                     2,262
      87  BACKUP          INACTIVE          STOPPED          DOWN              PID
3,262                                     2,262
->
```

Starting a Nonmirrored Disk Drive With SCF

Topic Home

Follow these instructions to start and verify a nonmirrored disk drive. In this example, the \$DATA21 disk drive has been replaced and is being returned to operation.

Use the SCF START DISK command to start the disk drive; then use the SCF STATUS DISK command to verify that both paths are in the STARTED state.

```
TACL> SCF START $DATA21
```

```
->STATUS $DATA21-*
```

```
STORAGE - Status DISK \TOYS.$DATA21-*
```

LDev	Path	Status	State	Substate	Primary PID	Backup PID
87	PRIMARY	ACTIVE	STARTED		2,262	3,262
87	BACKUP	INACTIVE	STARTED		2,262	3,262

```
->
```

Switching and Testing Paths to a Nonmirrored Disk Drive Using SCF

Topic Home

Follow these instructions to test all paths to a nonmirrored disk drive. In this example, the disk drive \$DATA21 has been replaced. The -P and -B paths are being tested before operations are resumed on the replacement disk drive CRU.

- 1 Use the SCF SWITCH DISK command to switch the replacement disk drive to its backup path; then use the SCF STATUS DISK command to verify that the disk path has been switched and is working properly:

```
TACL>SCF SWITCH $DATA21-B
->STATUS $DATA21-*
STORAGE - Status DISK \TOYS.$DATA21-*
LDev Path Status State Substate Primary Backup
PID PID
87 PRIMARY INACTIVE STARTED 2,262 3,262
87 BACKUP ACTIVE STARTED 2,262 3,262
->
```

- 2 Use the SCF PRIMARY DISK, FORCED command to switch the disk volume to its backup processor; then use the SCF STATUS DISK command to verify the operation:

```
->PRIMARY $DATA21, FORCED
->STATUS $DATA21-*
STORAGE - Status DISK \TOYS.$DATA21-*
LDev Path Status State Substate Primary Backup
PID PID
87 PRIMARY INACTIVE STARTED 3,262 2,262
87 BACKUP ACTIVE STARTED 3,262 2,262
->
```

i Note: For G06.10 and earlier, including the FORCED keyword here ensures the correct processor ownership. For G06.11 and later, the FORCED keyword is not needed and has no effect.

3 Use the SCF SWITCH DISK command again to switch the replacement disk drive back to its primary path; then use the SCF STATUS DISK command to verify that the disk path has been switched and is working properly:

```
->SWITCH $DATA21-P
->STATUS $DATA21-*
STORAGE - Status DISK \TOYS.$DATA21-*
LDev Path          Status      State      Substate      Primary      Backup
                PID              PID
    87 PRIMARY          ACTIVE     STARTED
    87 BACKUP          INACTIVE   STARTED      3,262        2,262
->
```

4 Use the SCF PRIMARY DISK, FORCED command again to switch the disk volume back to its primary processor; then use the SCF STATUS DISK command to verify the operation:

```
->PRIMARY $DATA21, FORCED
->STATUS $DATA21-*
STORAGE - Status DISK \TOYS.$DATA21-*
LDev Path          Status      State      Substate      Primary      Backup
                PID              PID
    87 PRIMARY          ACTIVE     STARTED
    87 BACKUP          INACTIVE   STARTED      2,262        3,262
->
```

 **Note:** For G06.10 and earlier, including the FORCED keyword here ensures the correct processor ownership. For G06.11 and later, the FORCED keyword is not needed and has no effect.

Checking For and Sparing Bad Sectors on a Nonmirrored Disk Drive With SCF

Topic Home

The following instructions describe how to check for and spare bad sectors on a replacement nonmirrored disk drive CRU before restoring data to it or allowing applications to use it.

- 1 SCF INFO \$DATA17, BAD
STORAGE - Bad Sector Information Magnetic DISK \TOYS.\$DATA17

Bad Sectors Information \$DATA17:

Logical Sector Address	Date Detected
%H0000795C	SEPTEMBER 22, 1996 15:25:12

File Name	File Address	Logical Sector Address
DLSYS42X.OSIMAGE	573440-573951	%H0000795C

Bad sectors are listed under Logical Sector Address. If no bad sectors are found, skip the remaining steps on this page.

- 2 If the disk has bad sectors, you must spare them using the CONTROL, DISK SPARE command:

```
->CONTROL $DATA17-P, SPARE %H795C
```



Caution: It is recommended that you all processing on the volume be stopped before issuing the CONTROL DISK, SPARE command.

- 3 Use the INFO DISK, BAD command again to verify that no new bad sectors have been introduced. (Repeat [Step 1](#)).