

Replacing and Installing Enclosure Doors and Side Panels

- [Description of Enclosure Doors and Side Panels](#)
- [Removing and Installing Enclosure Doors](#)
- [Installing a Service-Side Door Add-On Package](#)
- [Removing and Installing the Group ID Label](#)
- [Installing the Side Panels](#)

Description of Enclosure Doors and Side Panels

There are two types of enclosure doors: short doors and tall doors.

On some enclosures, a short door is installed on the appearance side of the enclosure. A short service side-enclosure door is optional, and the enclosures do not have removable side panels. The short doors are approximately 25 inches high and cover the mail chassis. A 6.75-inch-high removable panel is installed on the power shelf below the short door. See [Short and Tall Enclosure Doors](#)

On the other system enclosures, a tall enclosure door is installed on both the appearance-side and service-side of the enclosure. The doors are 33.75 inches high and cover the main chassis and power shelf. The appearance-side and service-side doors look the same on the outside but can be distinguished because the frames and louvers on the backs of the doors are different. Each row of enclosures has side panels installed on both ends. A stand alone enclosure has side panels installed on each side. See [Short and Tall Enclosure Doors](#), [Frames and Louvers on the Backs of Tall Doors](#), and [Tall Doors and Side Panels Installed on an End Enclosure](#).

Note:

- Any system enclosure can be ordered with either the short or tall doors, and either door can be ordered as an upgrade.
- The doors are installed on hinge pins on the left side of the enclosure frame. On the service side of an enclosure, the hinge pins are part of an adapter frame that is mounted on the cable channel frame. The adapter frame is part of the service-side door add-on package. See [Installing a Service-Side Door](#).
- Two kits are provided for installing the tall doors:
 - The internal enclosure kit: contains an appearance-side door, a service-side door, an adapter frame, and mounting hardware.
 - The end enclosure kit: contains two side panels and their mounting

hardware, an appearance-side door, a service-side door, an adapter frame, and mounting hardware.



Caution:

- To avoid overheating, minimize the time the appearance-side enclosure door is open. See [Safe Operating Times With Enclosure Door Open](#).
- Use appropriate ESD precautions and follow standard operating practices. (See [ESD Guidelines](#) and [Standard Operating Practices](#).)

Related Topics:

- [Quiescing Customer Applications](#)
- Definitions and Service Classes of CRUs and FRUs
- Part Number List for NonStop S-Series CRUs
- Part Number List for NonStop S-Series FRUs

Removing and Installing Enclosure Doors

- 1 If a service-side door is being added and the adapter frame is not already installed, see [Installing a Service-Side Door Add-On Package](#).
- 2 Inspect the door being installed. If the door is damaged, order a new door.
- 3 If you are removing a door:
 - a. Unlock and open the door. See [Unlocking and Opening a System Enclosure Door](#).
 - b. To remove a door, see [Removing an Enclosure Door](#).
 - c. If a short door is being replaced with a tall door, also remove the power shelf panel below the door.
- 4 To Install a door, see [Installing an Enclosure Door](#).
- 5 Install the group ID label. See [Removing and Installing the Group ID Label](#).
- 6 Close and lock the enclosure door you just installed.

Installing the Side Panels

- 1 a. You need these tools:
 - Phillips head screwdriver (medium size)
 - T-25 Torx head screwdriver (for M5 Torx screws)
- b. For each enclosure, you need the following items from a 7285 full-upgrade kit:
 - 2 side panels
 - 2 large brackets
 - 2 small brackets
 - 8 0.375-inch Phillips self-tapping screws
- 2 On the side of the enclosure where you are installing the panel, install the brackets:
 - a. Position one large bracket at the top of the enclosure side and center it between the front and back. See [Brackets on the Side of an End Enclosure](#).
 - b. Insert 2 Phillips head screws through the bottom holes on the bracket into the bottom row of perforations.
 - c. Insert 2 more Phillips screws into the remaining bracket holes.
 - d. Install one small bracket near the bottom of the enclosure side, using the 2 existing M5 Torx screws already installed on the enclosure. See [Brackets on the Side of an End Enclosure](#).
- 3 If you are installing side panels on both enclosures of a double high enclosure stack, repeat Step 2 to install brackets on the other enclosure of the stack. See [Brackets on the Side of Stacked End Enclosures](#).
4. Install a side panel on the enclosure (for a double-high enclosure stack, **install the side panel on the bottom enclosure first**):
 - a. Examine the back of the side panel and make sure the mounting brackets and foam strip are secure. See [Front and Back Views of Side Panel](#).
 - b. Lift the side panel into position and slide it down until its mounting brackets engage with the brackets on the enclosure. See [Tall Doors and Side Panel Installed On an End Enclosure](#).
- 5 For a double-high enclosure stack, repeat Step 4 to install the side panel on the top enclosure.

- 6 If you are installing side panels on both sides of an enclosure or stack, repeat steps 2 through 5 to install the remaining side panels on the other side.

Installing a Service-Side Door Add-on Package

Preparing to Install a Service Side Door:

These instructions described how to replace the short system enclosure doors with tall system enclosure doors. You need a Phillips screwdriver and a T-125 Torx screwdriver.

There are two kits:

- The 7285 full-upgrade kit contains two doors and two side panels.
- The 7286 partial-upgrade kit contains two doors.

Install the Service Side Door

- 1 Unpack the upgrade kit and verify that all items are present. Both upgrade kits contain these items for installing doors:
 - A tall service side-door
 - An adapter frame for the service-side door
 - A tall appearance side-door
 - Group ID labels
 - 4 M5 PNHD Phillips screws
 - 4 M5 KEPS nuts
 - 4-mm hex-key wrench, for unlocking the door
 - Read Me Instructions

The 7285 full-upgrade kit also contains the components for installing side panels.

- 2 If you are replacing the service side door, remove and discard the existing door from the service side of the enclosure. (Return to Step 2 of [Removing and Installing Enclosure Doors](#).)

Install the adapter frame on the Enclosure:

- 3 Position the adapter frame on the enclosure:
 - a. Position the adapter frame on the outside of the cable channel frame.
 - b. Align the mounting hooks on the adapter frame with the enlarged holes near the top of the cable channel frame.
 - c. Push the adapter frame in and down so that the mounting hooks engage and support the adapter frame.
 - d. Verify that the adapter frame is flush against the cable channel frame and that the screw holes are aligned.

- 4 Install 4 M5 Phillips screws and 4 M5 KEP nuts on the adapter frame:

See [Installing a Screw and KEP Nut on an Adapter Frame](#) and [Securing an Adapter Frame to an Enclosure](#).

 - a. Insert a Phillips screwdriver through an access hole in the adapter frame.
 - b. Use the screwdriver to insert a Phillips screw in the hole.
 - c. Hold the screw in position using the screwdriver, and from the inside of the cable channel, install a KEP nut on the end of the screw.
 - d. Hold the KEP nut, tighten the screw, and then back it off 1/4 turn.
 - e. Install the remaining KEP nuts in the same way, and then fully tighten the screws.

- 5 Return to Step 2 of [Removing and Installing Enclosure Doors](#).

Figure: Installing a Screw and KEP Nut on an Adapter Frame

Insert the screw into the screw hole:

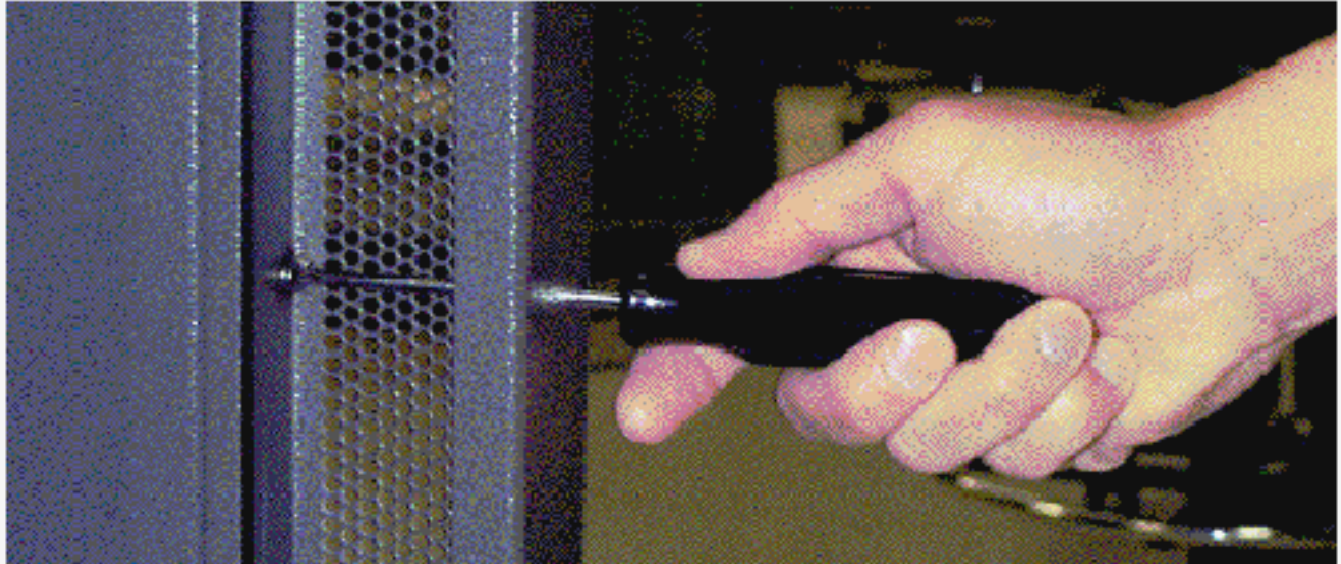

From the inside of the cable channel, install a KEP nut on the end of the screw:

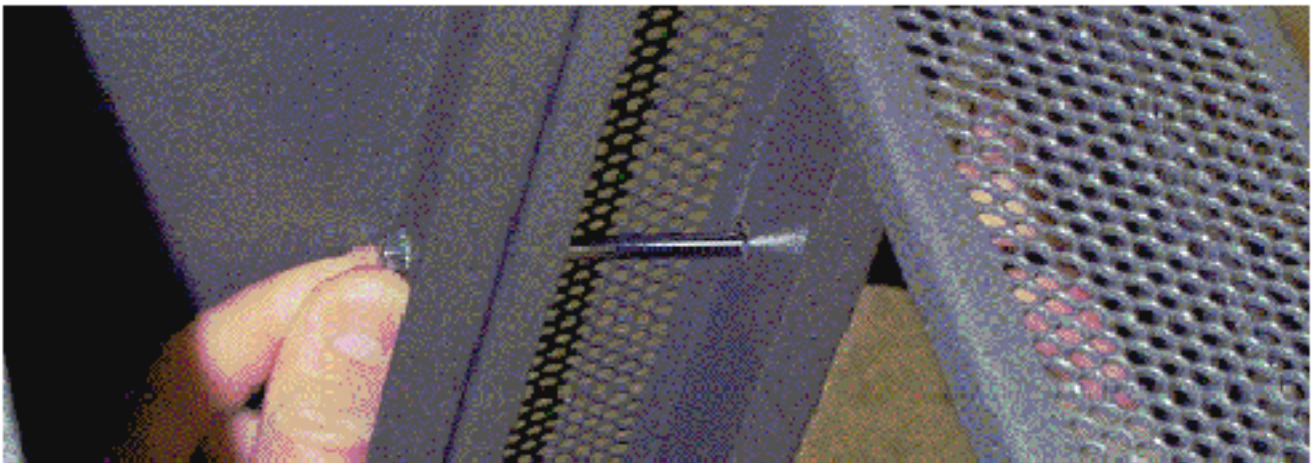

Figure: Securing an Adapter Frame to an Enclosure

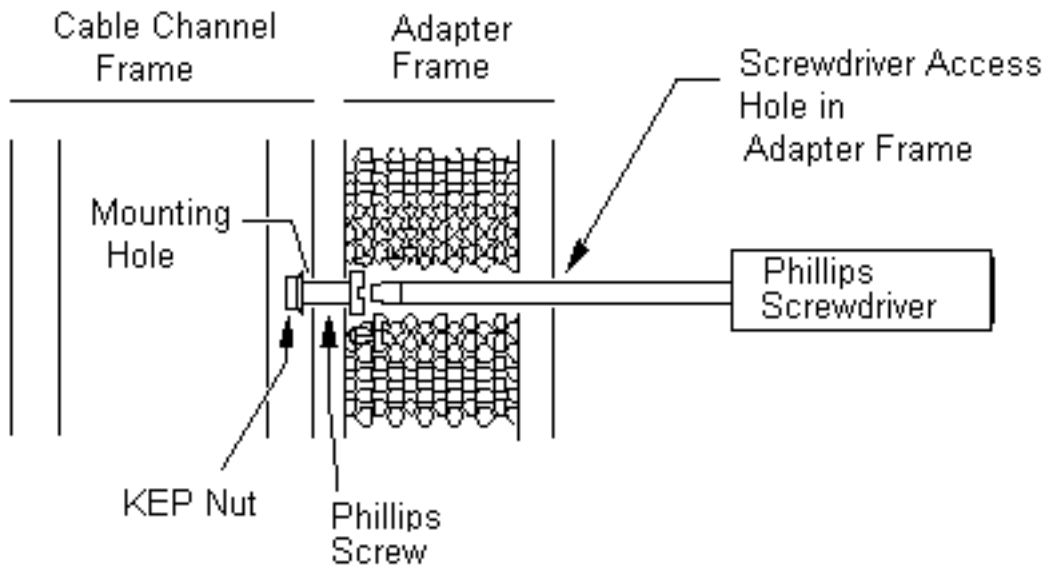
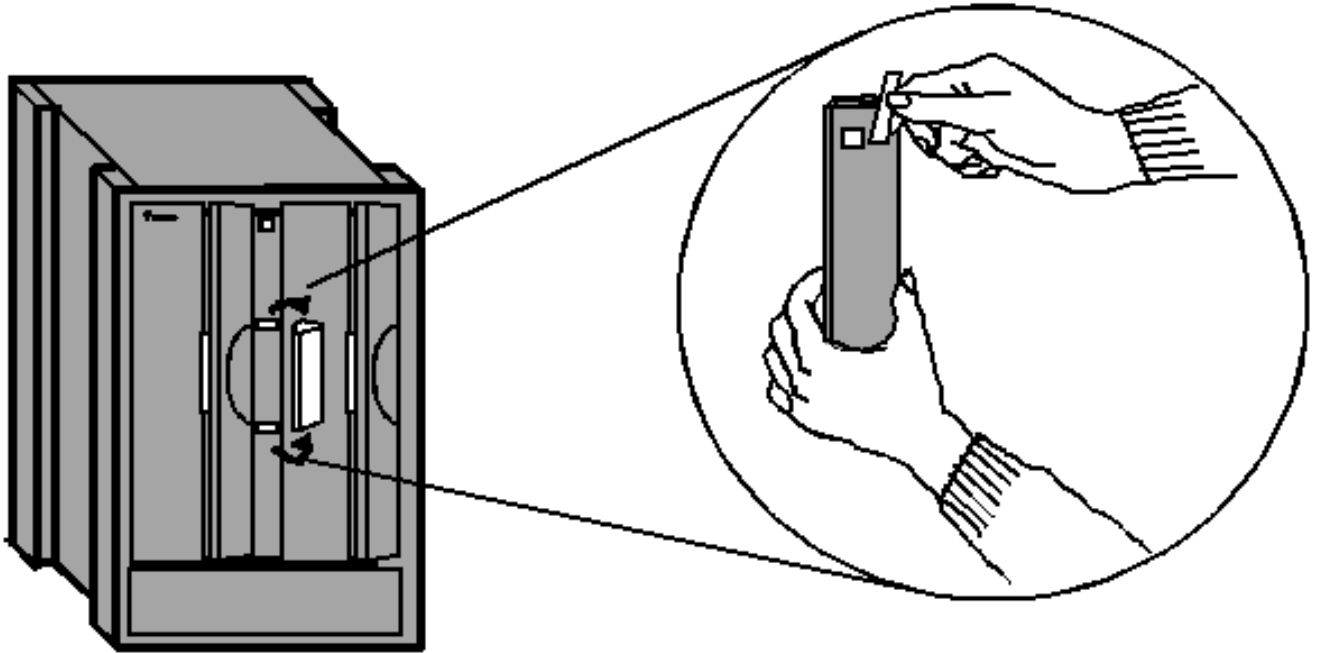

Figure: Removing and Installing the Group ID Label

- 1 Remove the faceplate by squeezing its top and bottom surfaces to disengage the locking tabs.
- 2 Remove the group ID label from the faceplate.
- 3 Select the correct group ID label for this enclosure from the labels provided.
- 4 Insert the label into the faceplate.
- 5 Reinstall the faceplate on the door.



Removing the Faceplate

Removing the Group ID Label

Figure: Short and Tall Enclosure Doors

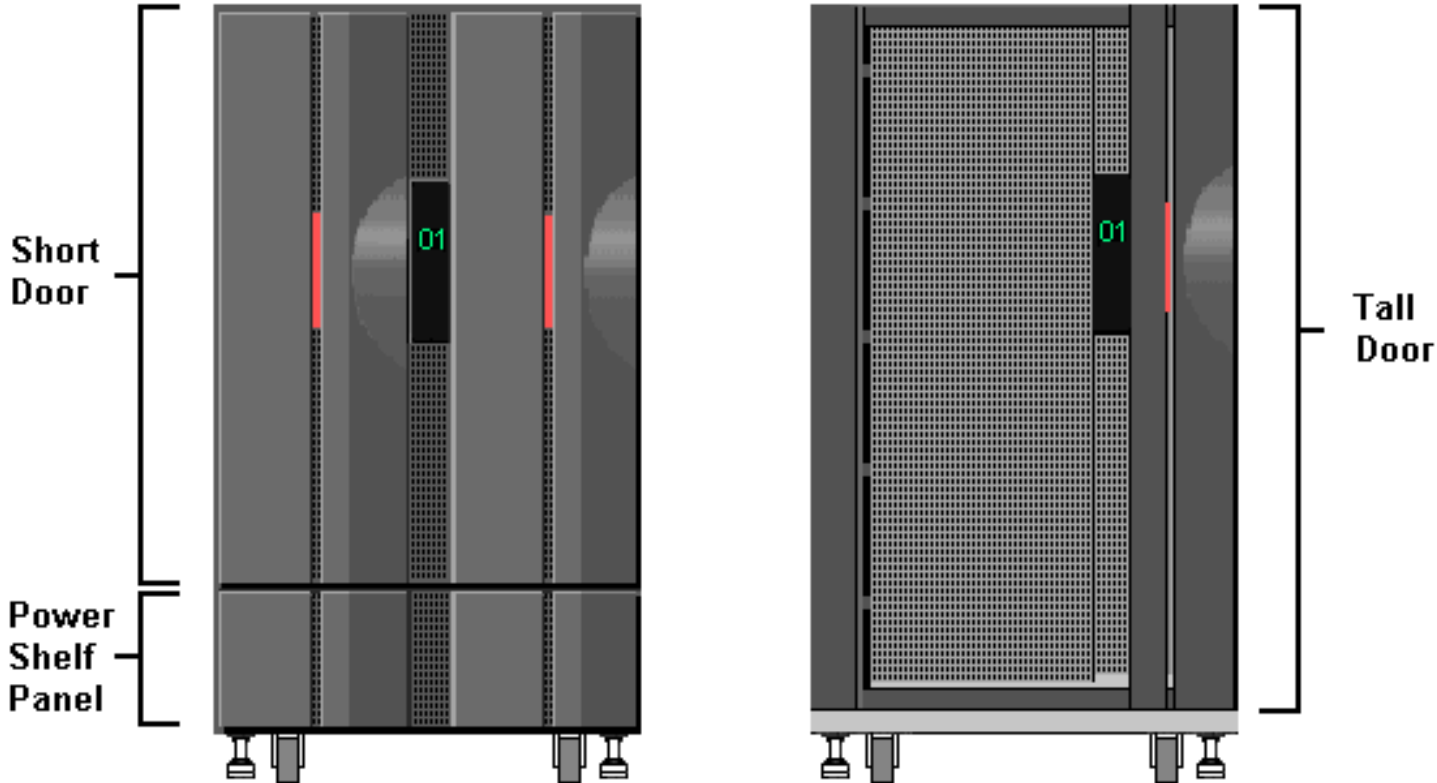
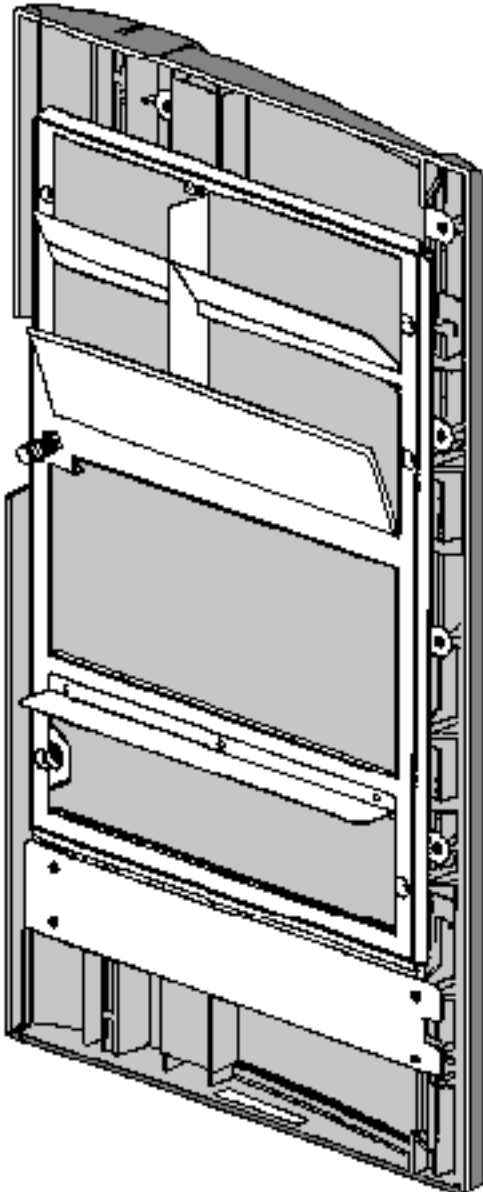

Figure: Frames and Louvers on the Backs of Tall Doors

Appearance-Side Door



Service-Side Door

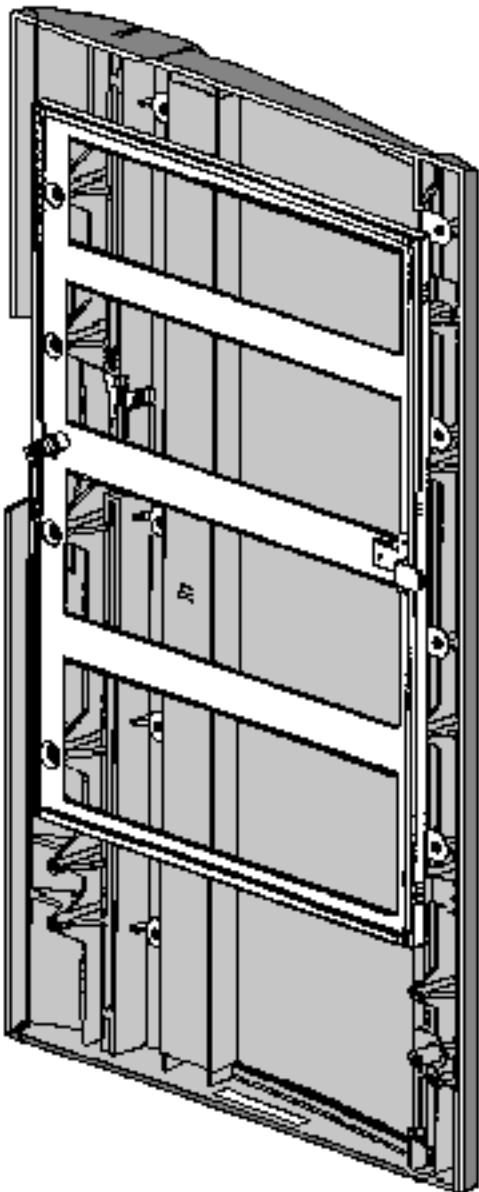

Figure: Tall Doors and Side Panel Installed On an End Enclosure

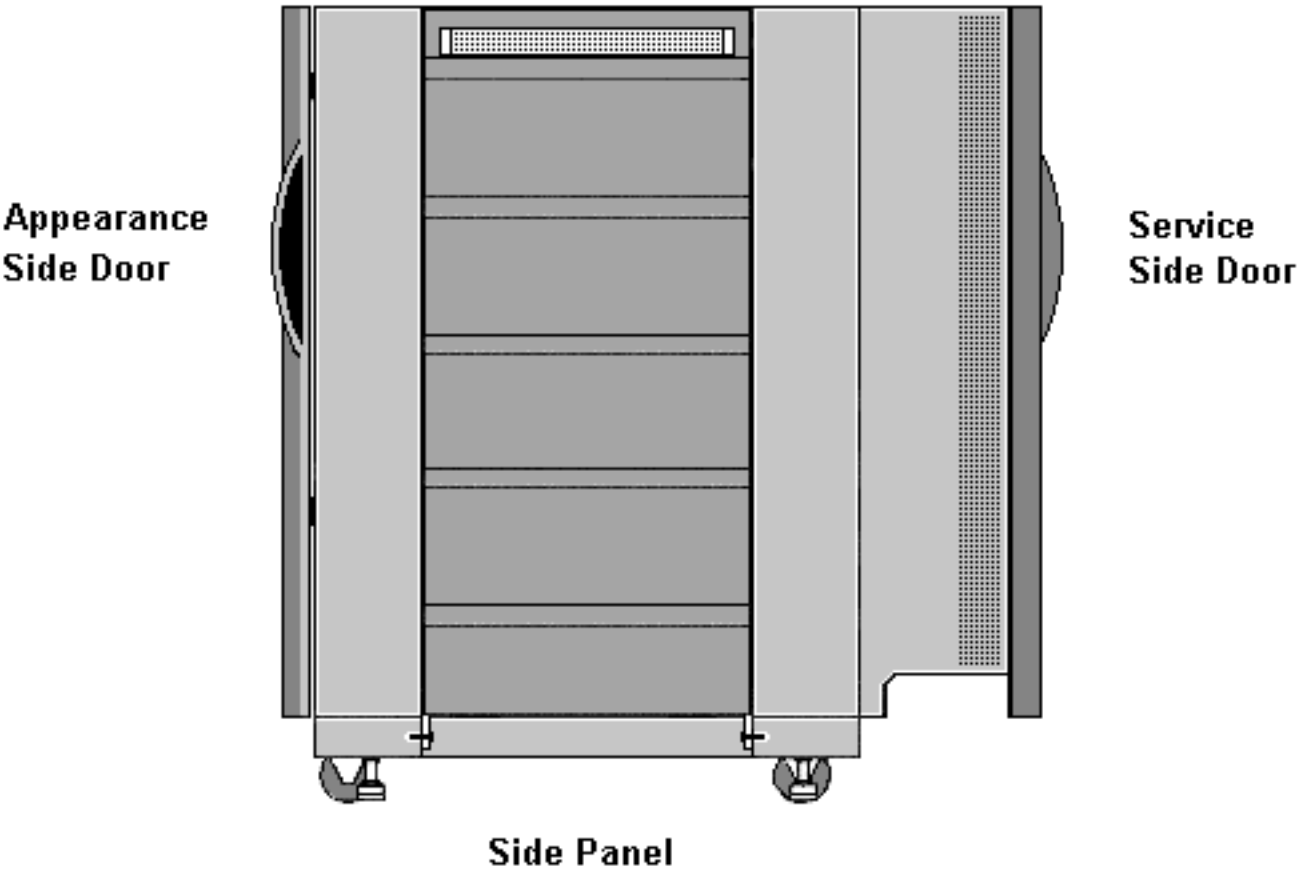
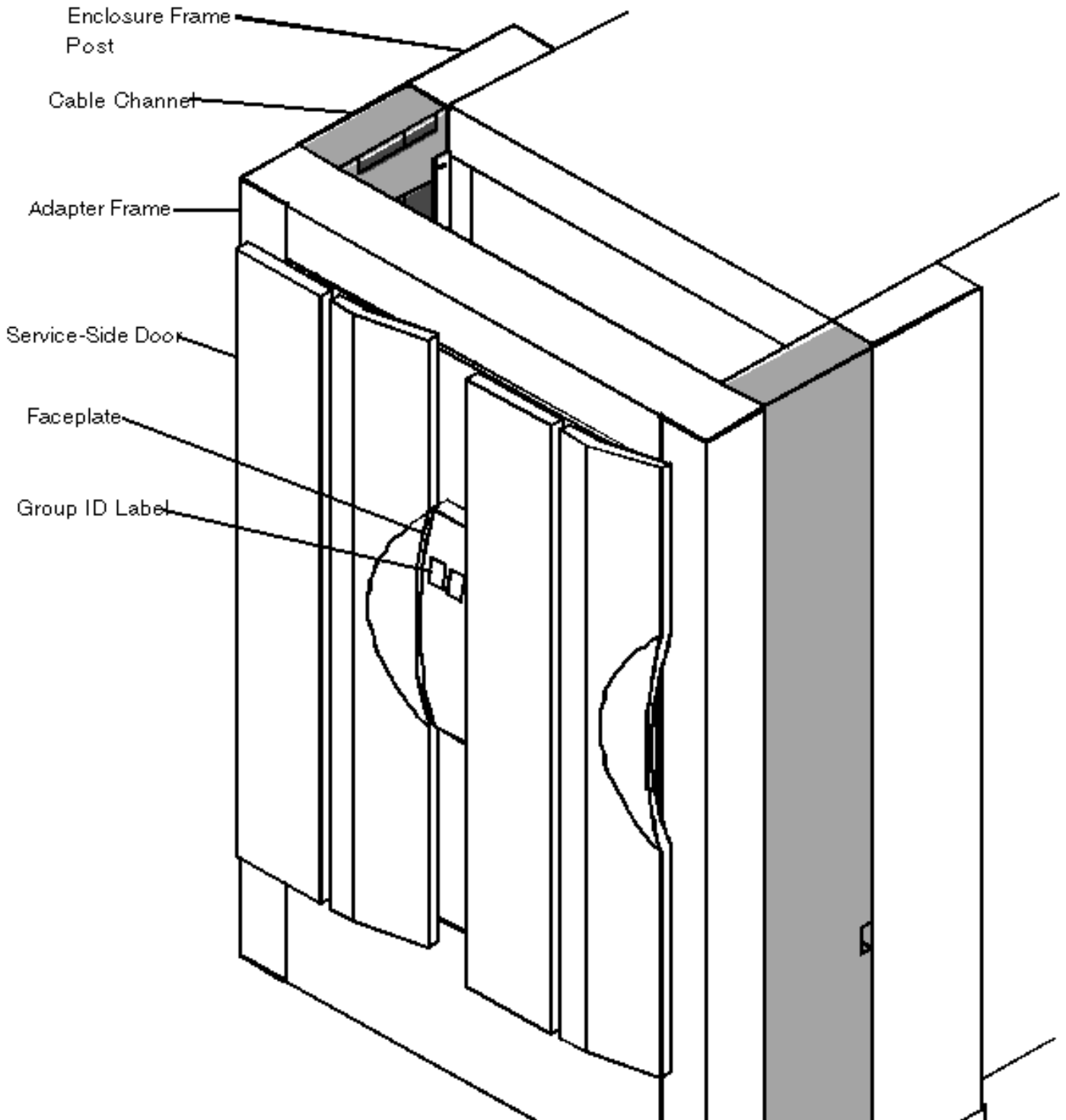

Figure: Installing a Service-Side Door

The service-side door covers the cable channel frame and CRU access. It is not required for EMI compliance or cooling.

- When a short appearance-side door is installed, the short service-side door is optional.
- When a tall appearance-side door is installed, a tall service-side door is required.

i Note: The short door is shown in this figure.





VST000.vsd

Standard Operating Practices



Caution. Replace only one CRU or FRU at a time. Attempting to replace more than one hardware component at a time might cause serious system outages, processor halts, and connectivity problems.

Whenever you replace a CRU or a FRU, use the following standard operating practices to minimize any potential damage to the equipment:

- Complete HP training courses on system support for NonStop S-series servers.
- Inspect the replacement CRU or FRU for any physical damage before installing it. Check the connectors on the CRU, FRU, or backplane for bent or broken pins and for any other obvious damage. If there is damage to the CRU or FRU, you need to order another one.
- Remove all jewelry and metal accessories, such as rings, watches, and necklaces, before working with the equipment. These items can damage electrical equipment or result in personal injury.
- Restrain any dangling items that can get caught in electromechanical equipment, such as long hair and sleeves, before working with the equipment.
- Follow the [ESD Guidelines](#) for working in an electrostatic discharge (ESD)-protected environment and for handling CRUs and FRUs.
- Avoid permanent damage to components from overheating by observing the time limits for an enclosure door to be open with only one fan running.

The following table indicates the amount of time that components in a fully loaded NonStop S-series system enclosure, with the appearance-side door open and only one fan operating, can operate before overheating.

Safe Operating Times With Enclosure Door Open

Altitude	Ambient Room Temperature			
	25°C (77°F)	30°C (86°F)	35°C (95°F)	38°C (100°F)
Sea level	>45 minutes	36 minutes	21 minutes	13 minutes
1,524 meters (5,000 feet)	38 minutes	22 minutes	13 minutes	8 minutes
3,048 meters (10,000 feet)	25 minutes	14 minutes	10 minutes	5 minutes

For example, if your computer room has an ambient room temperature of 25°C (77°F) and is at an altitude of 1,524 meters (5,000 feet), you have approximately 38 minutes to replace or reinstall the second fan before components inside a system enclosure overheat.

Related Topic

[ESD Guidelines](#)

ESD Guidelines



Figure: [Working in an ESD-Protected Environment](#)

Observe the following electrostatic discharge (ESD) guidelines whenever servicing electronic components:

- Obtain an ESD protection kit and follow the directions that come with the kit. You can purchase an ESD kit from HP (T99247-A00) or from a local electronics store. Ensure that your ESD wriststrap has a built-in series resistor and that the kit includes an antistatic table mat.
- Before you unpack a replacement CRU or FRU, place the CRU or FRU package on the antistatic table mat and attach the grounding clip on your wriststrap to the mat.
- When you unpack the CRU or FRU, do not cut into the ESD protective bag surrounding the CRU or FRU. The protective bag protects the CRU or FRU and can be reused for storing the CRU or FRU that has been replaced.
- Before you move the CRU or FRU from the antistatic table mat, attach the grounding clip from your ESD wriststrap to any unpainted metal surface on the CRU or FRU frame.
- Before you bring a CRU or FRU in contact with a system enclosure, attach the grounding clip on your ESD wriststrap to any unpainted metal surface on the enclosure frame.
- When you remove a CRU or FRU from a system enclosure, first pull the CRU or FRU partway out of the slot and then attach the grounding clip on your ESD wriststrap to any unpainted metal surface on the CRU or FRU frame.
- Store CRUs or FRUs that require ESD protection in ESD protective bags.
- The figure [Working in an ESD-Protected Environment](#) illustrates how to use an ESD kit when servicing CRUs or FRUs.

i Note: An ESD protection kit can be purchased from HP using the following order number and part number:

Order Number: ESD-kit

Part Number: T99247-A00

Related Topic

[Standard Operating Practices](#)

Figure: Working in an ESD-Protected Environment

This figure illustrates how to use an ESD kit when servicing customer-replaceable units (CRUs) and field-replaceable units (FRUs).

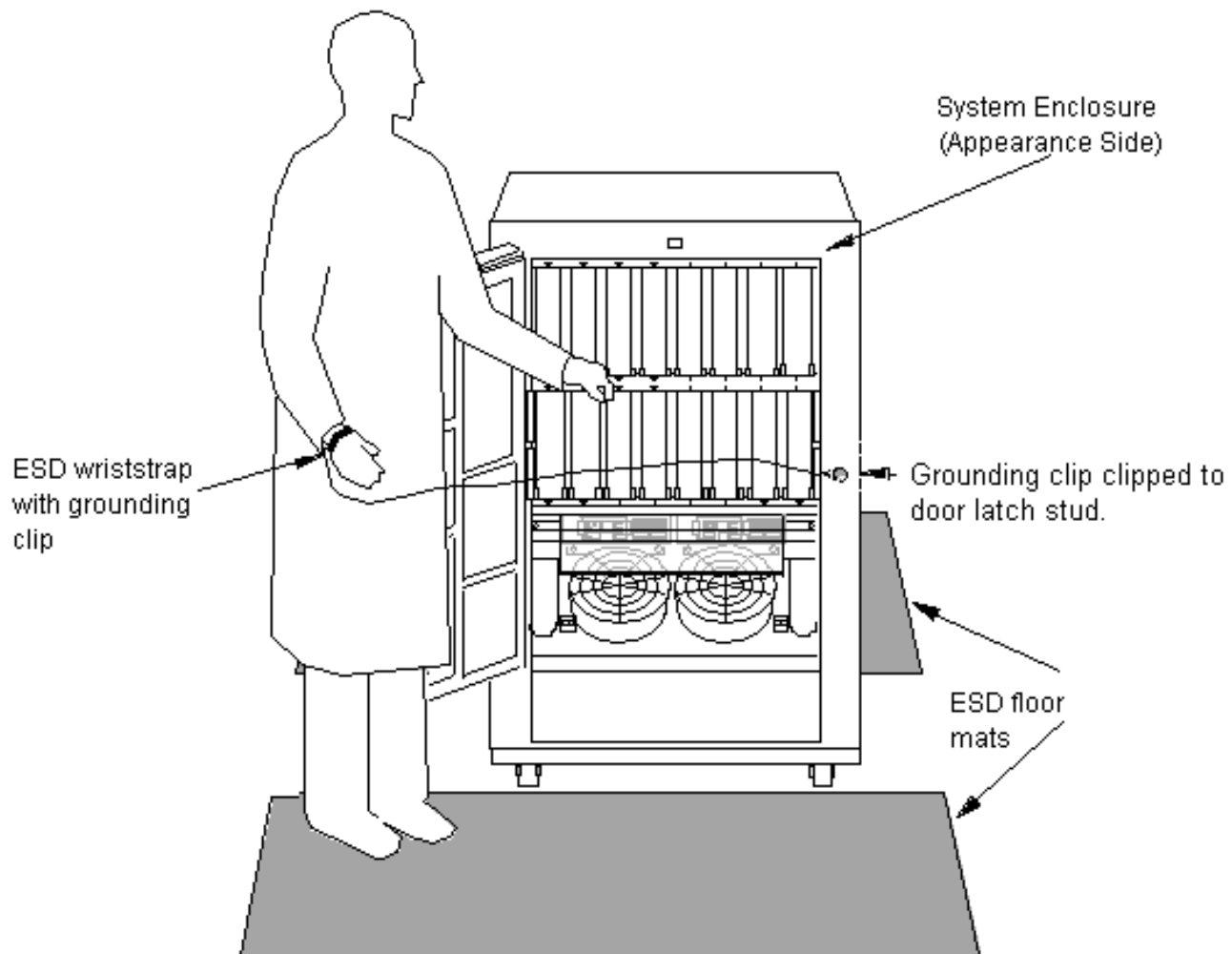

ESD antistatic table mat.
Mat should be connected
to a soft ground (1 megohm min.
to 10 megohm max.)

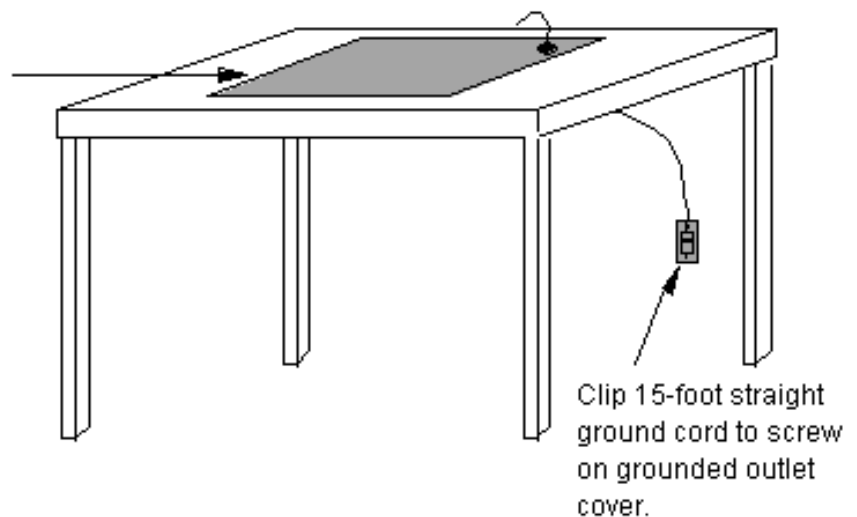

Quiescing Customer Applications

- 1 Notify end users that applications will be temporarily unavailable.
- 2 Perform any actions necessary to quiesce customer applications.

 **Note:** The actions required to perform this step depend on the customer's application.

Figure: Unlocking and Opening a System Enclosure Door

i Note: The same key works for both tall and short doors (tall door is not shown).

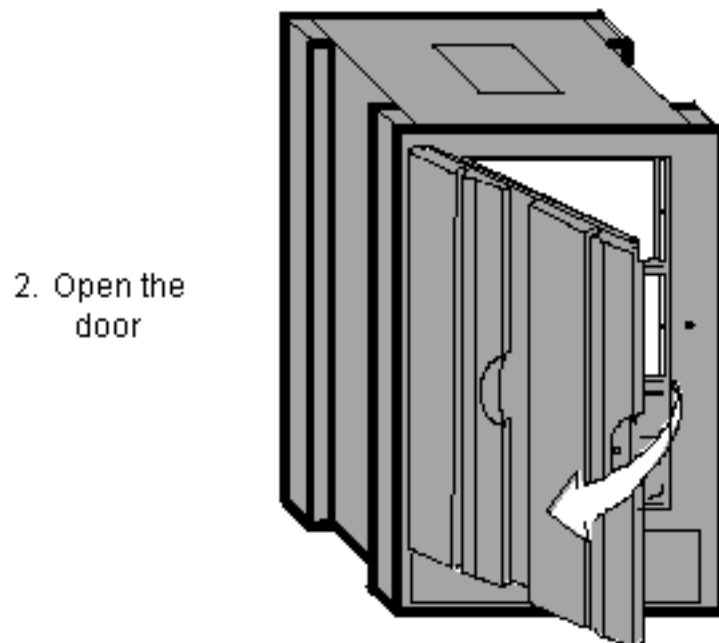
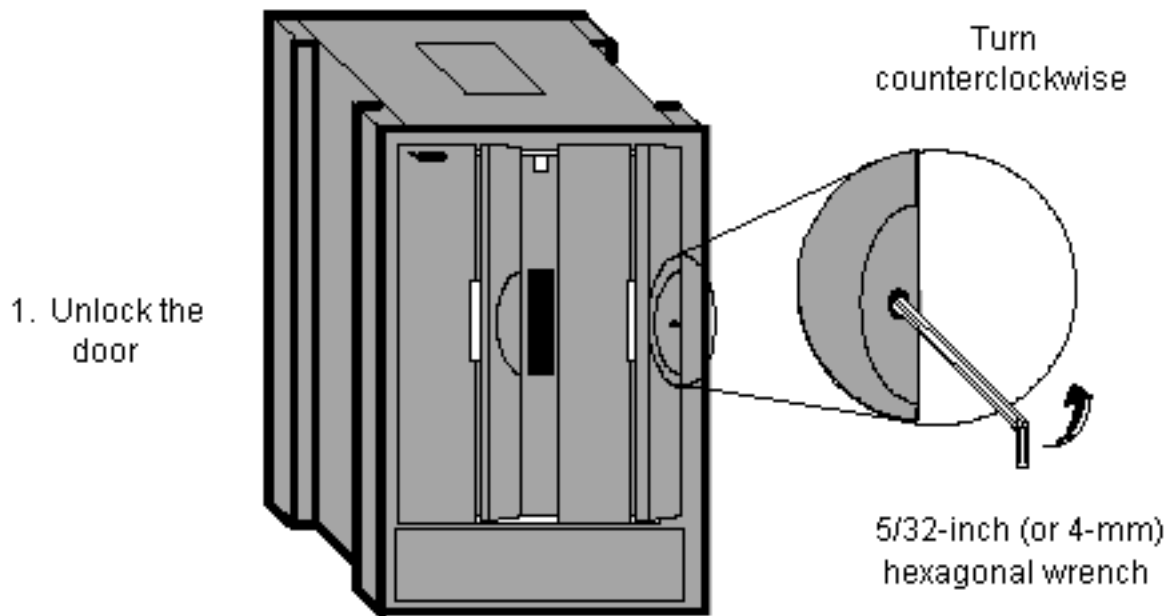

Figure: Removing an Enclosure Door

1. Open the door partway (45 degrees to the enclosure).
2. Using both hands, grasp the door on the side opposite the hinge and on the bottom near the hinge pins. Lift the door to unseat the hinge pins, and remove the door.

i Note: This procedure is for both tall and short doors (tall door is not shown).

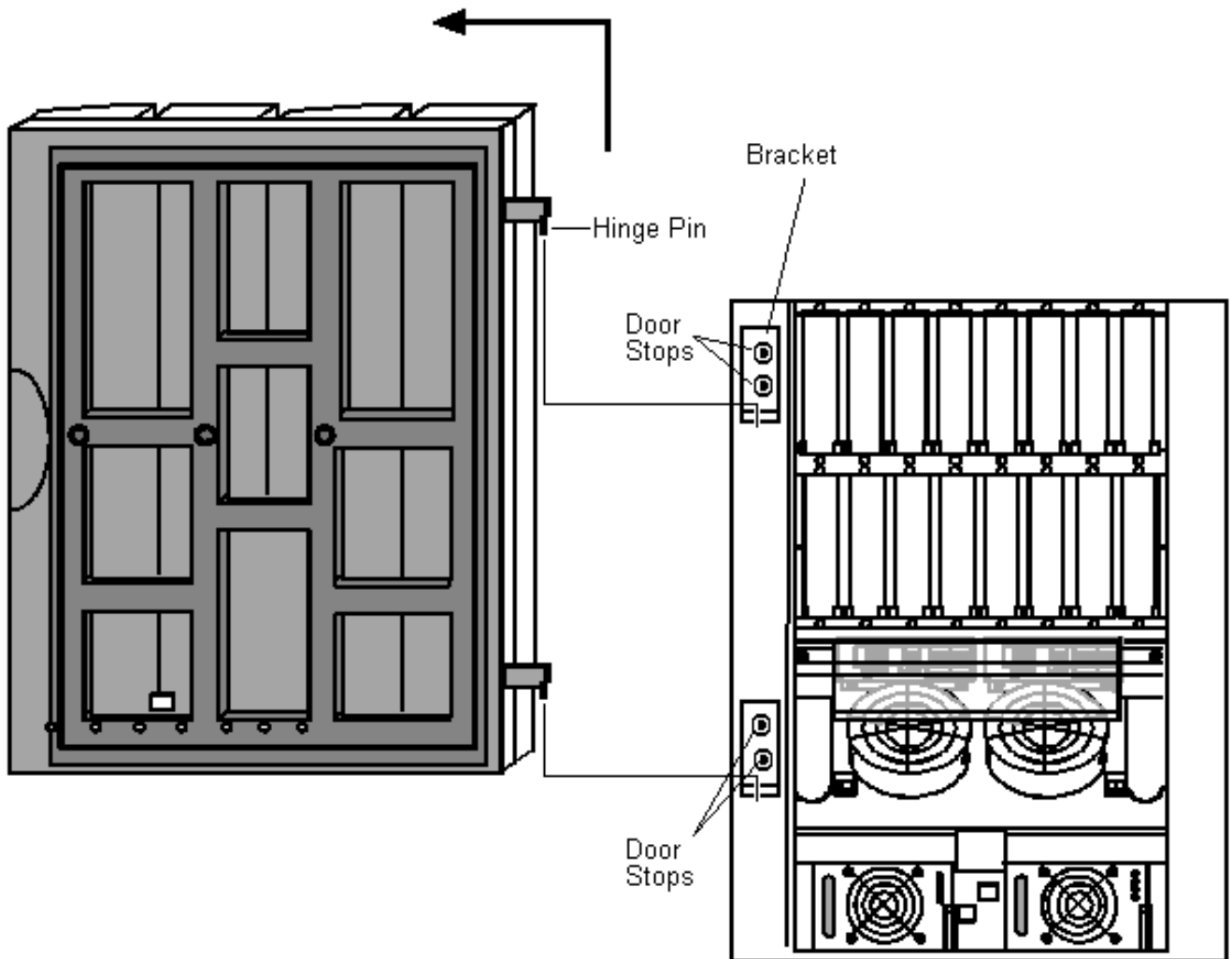

Figure: Installing an Enclosure Door

1. Grasp the door with both hands and lift it into position.
2. Align the hinge pins on the door with the holes in the enclosure brackets.
3. Insert the top (long) hinge pin first, and then insert the bottom hinge pin.
4. Lower the door and engage the hinges.
5. Close the door to check that it is correctly installed.

i Note: This procedure is for both tall and short doors (tall door is not shown).

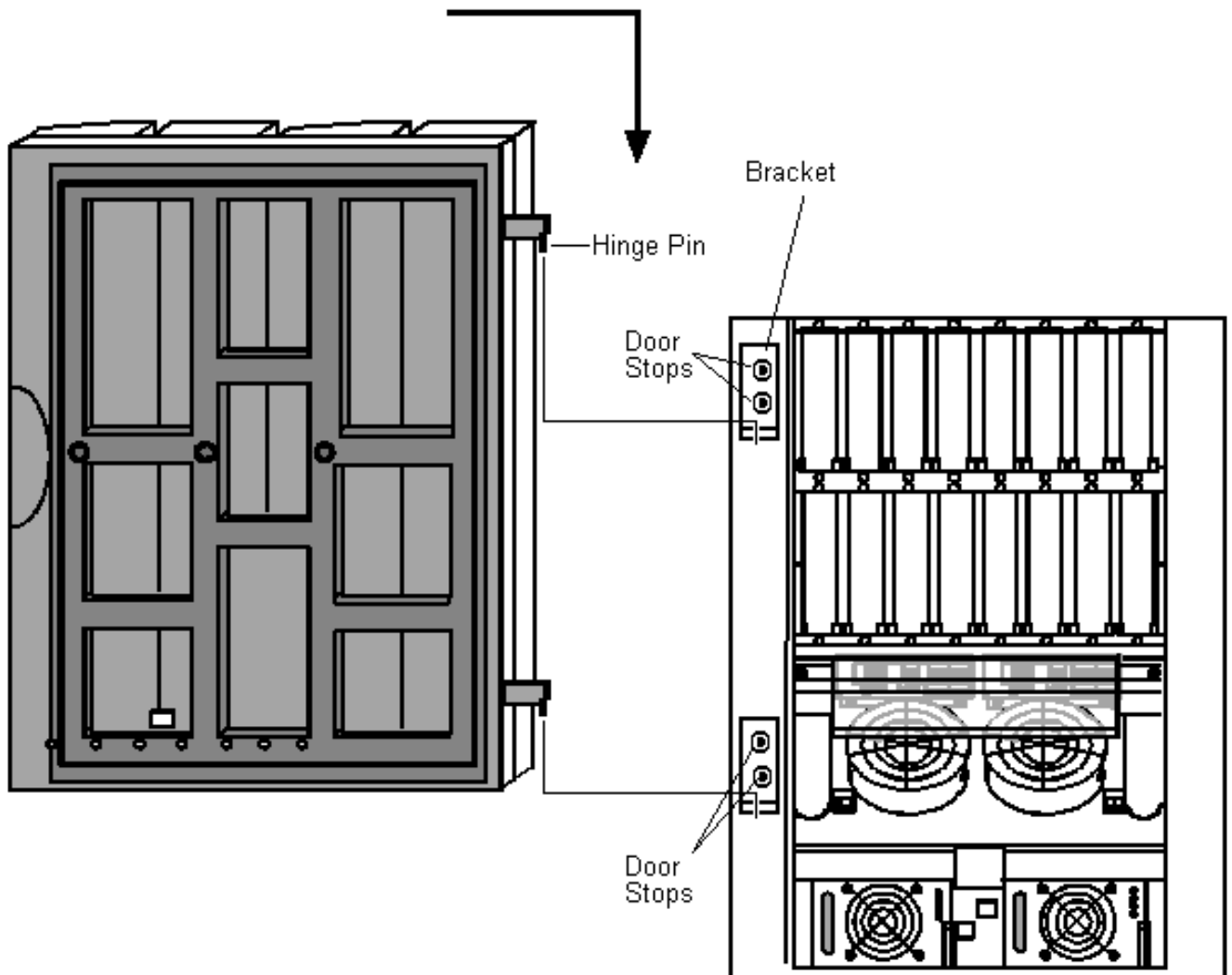

Figure: Brackets on the Side of an End Enclosure

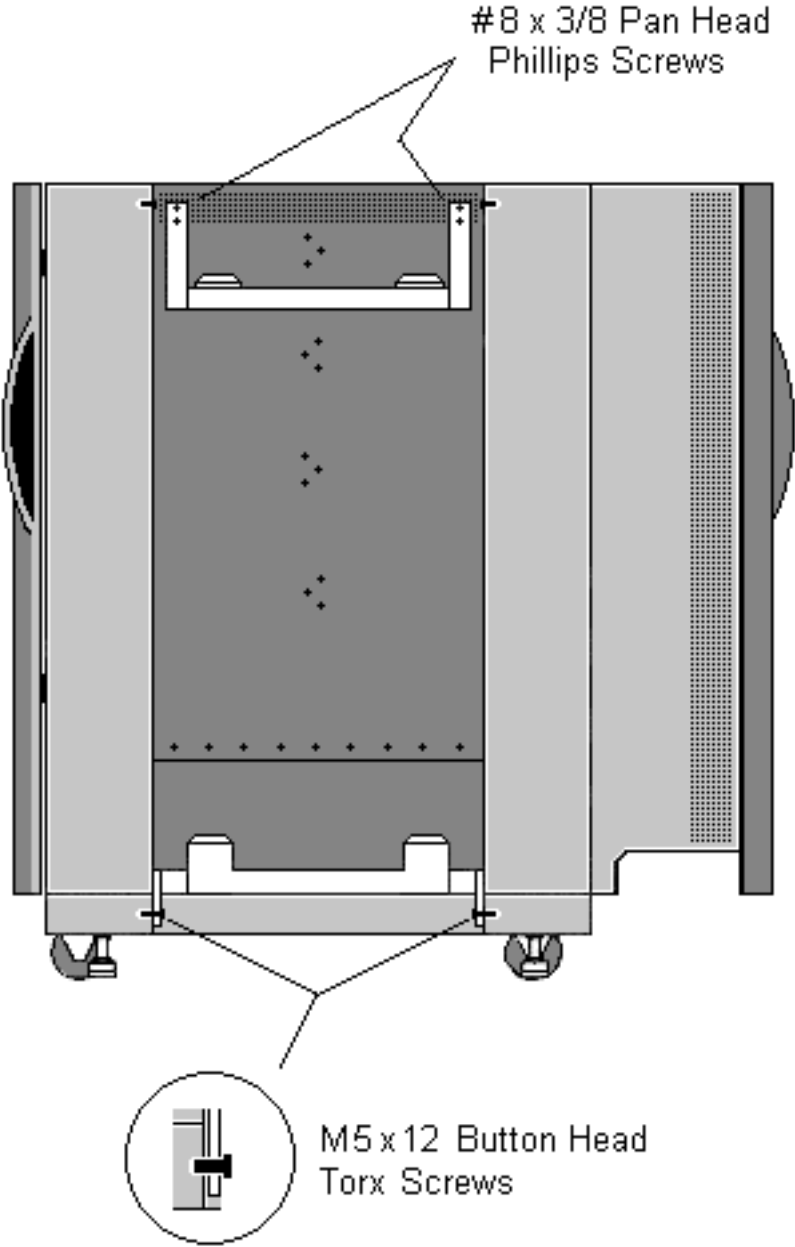

Figure: Brackets on the Side of Stacked End Enclosures

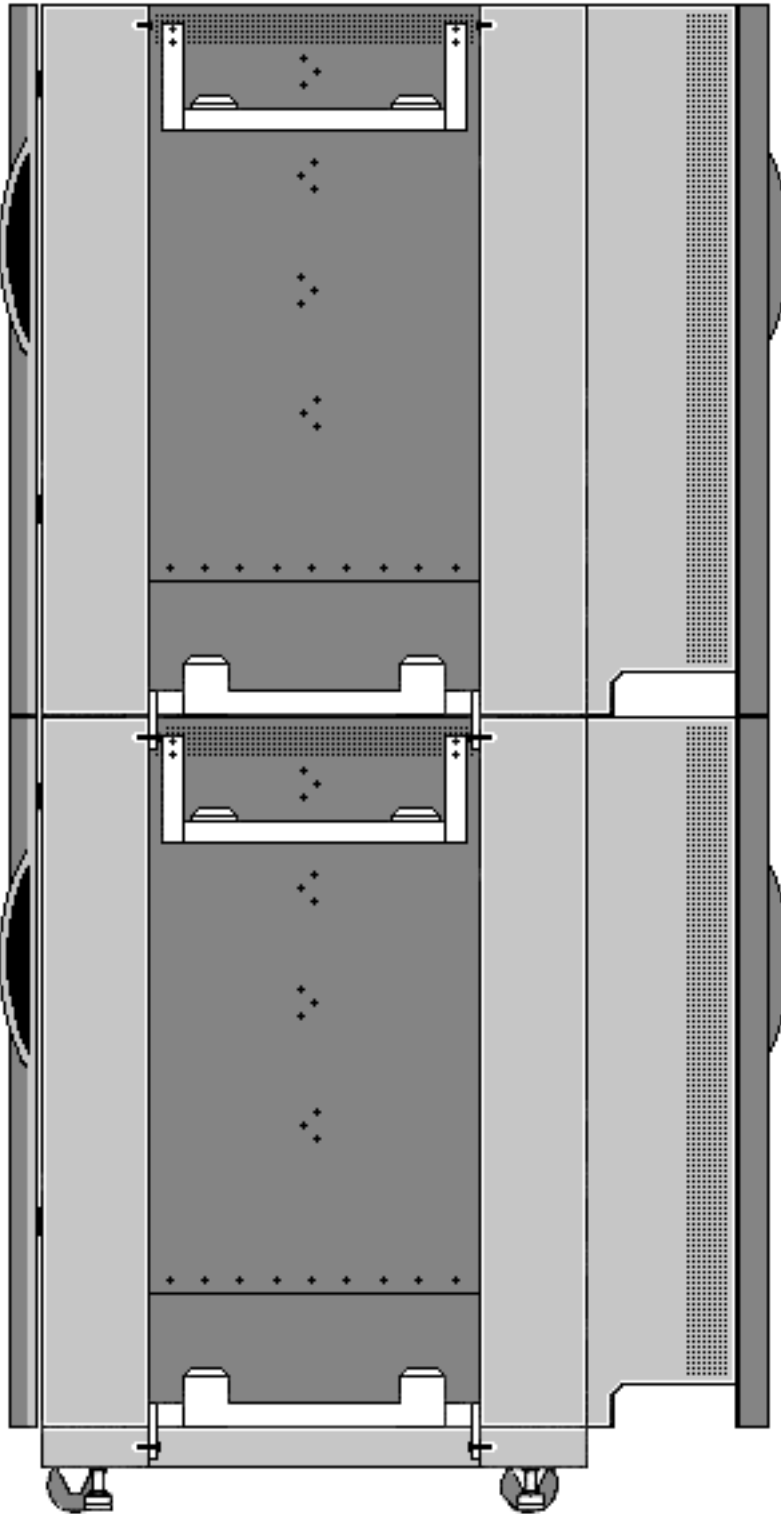

Figure: Front and Back Views of Side Panel

